

ATTACHMENTS

Ordinary Council Meeting

Wednesday, 24 April 2024

Table of Contents

9.2.1	Monthly Financial Statements - March 2024	
	Attachment 1 Monthly Financial Statement as at 31 March 2024; and	4
	Attachment 2 Supplementary Information as at 31 March 2024.	14
9.2.2	List of Payments - March 2024	
	Attachment 1 Creditors Payments Listing - March 2024	29
9.2.3	Request for Write Off - Toodyay Tennis Club	
	Attachment 4 Request for Fee Waiver - Toodyay Tennis Club.	47
9.3.1	Department of Local Government, Sport & Cultural Industries correspondence	
	Attachment 1 DLGSC Correspondence.	48
9.4.1	Schedule of Preventative Maintenance Fire Stations	
	Attachment 1 Schedule of Preventative Maintenance.....	50
9.4.2	Toodyay Racecourse Precinct - Main Building Roof Resheeting	
	Attachment 1 Existing Structure Toodyay Race Club Precinct Toodyay Structural Report;	51

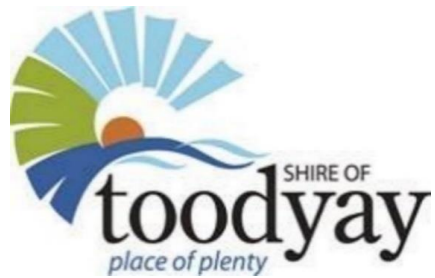

SHIRE OF TOODYAY
MONTHLY FINANCIAL REPORT
(Containing the required statement of financial activity and statement of financial position)
FOR THE PERIOD ENDED 31 MARCH 2024

LOCAL GOVERNMENT ACT 1995
LOCAL GOVERNMENT (FINANCIAL MANAGEMENT) REGULATIONS 1996

TABLE OF CONTENTS

Statements required by regulation

Statement of Comprehensive Income-By Nature	2
Statement of Financial Activity	3
Statement of Financial Position	4
Note 1 Basis of Preparation	5
Note 2 Statement of Financial Activity Information	6
Note 3 Explanation of Material Variances	7

SHIRE OF TOODYAY

A caring and visionary rural community, working together to preserve and enrich
Toodyay's environment, character and lifestyle.

SHIRE OF TOODYAY
STATEMENT OF COMPREHENSIVE INCOME
BY NATURE OR TYPE
FOR THE PERIOD ENDED 31 MARCH 2024

	2023/24 Actual(a)	2023/24 Revised Adopted Budget	2023/24 YTD Budget(b)	2022/23 Actual	Var.\$ (b)-(a)	Var. % (b)- (a)/(a)
Rates	7,597,115	7,604,776	7,584,920	7,068,483	12,195	0%
Operating Grants, subsidies and contributions	1,091,778	932,598	363,650	3,376,535	728,128	200%
Fees and charges	1,476,236	1,459,737	1,297,820	1,427,209	178,416	14%
Interest revenue	172,932	220,000	113,730	178,229	59,202	52%
Other revenue	252,538	358,458	240,902	384,975	11,636	5%
	10,590,599	10,575,568	9,601,022	12,435,431	989,577	10%
Expenses						
Employee costs	(2,978,365)	(4,175,838)	(2,866,450)	(4,191,693)	(111,915)	4%
Materials and contracts	(3,656,465)	(4,577,336)	(3,409,280)	(4,068,860)	(247,185)	7%
Utility charges	(402,996)	(437,903)	(303,500)	(447,625)	(99,496)	33%
Depreciation	2,643	(4,436,148)	(2,957,460)	(3,542,172)	2,960,103	(100%)
Finance costs	(73,674)	(144,447)	(96,360)	(165,717)	22,686	(24%)
Insurance	(443,893)	(448,380)	(340,043)	(381,835)	(103,850)	31%
Other expenditure	(178,848)	(264,593)	(202,440)	(266,734)	23,592	(12%)
	(7,731,597)	(14,484,645)	(10,175,533)	(13,064,635)	2,443,936	(24%)
	2,859,002	(3,909,077)	(574,511)	(629,204)	3,433,513	(598%)
Non Operating Grants, subsidies and contributions	974,615	3,268,721	2,396,760	2,523,972	(1,422,145)	(59%)
Profit on asset disposals	0	0	0	84000	0	0%
Loss on asset disposals	0	0	0	(182,240)	0	0%
Fair value adjustments to financial assets at fair value through profit or loss	0	0	0	2764	0	0%
	974,615	3,268,721	2,396,760	2,428,496	(1,422,145)	(59%)
Net result for the period	3,833,617	(640,356)	1,822,249	1,799,293	2,011,368	110%
Other comprehensive income						
Changes in asset revaluation surplus	0	0		2,445,794	0	0%
Total other comprehensive income for the period	0	0	0	2,445,794	0	0%
Total comprehensive income for the period	3,833,617	(640,356)	1,822,249	4,245,087	2,011,368	110%

This statement is to be read in conjunction with the accompanying notes.

SHIRE OF TOODYAY

STATEMENT OF FINANCIAL ACTIVITY

	2023/24	2023/24	2023/24	Var.\$	Var.%	2022/2023
	Actual(a)	Revised Adopted Budget	YTD Budget(b)	(a)-(c)	(a)-(b)/(b)	Actual
OPERATING ACTIVITIES						
Revenue from Operating Activities						\$
Rates	7,597,115	7,604,776	7,584,920	12,195	(0%)	7,068,483
Operating Grants, subsidies and contributions	1,091,778	932,598	363,650	728,128	(67%)	3,376,535
Fees and charges	1,476,236	1,459,737	1,297,820	178,416	(12%)	1,427,209
Interest revenue	172,932	220,000	113,730	59,202	(34%)	178,229
Other revenue	252,538	358,458	240,902	11,636	(5%)	384,975
Profit on asset disposals	0	0	0	0	0%	84,000
Fair value adjustments to financial assets at fair value through profit or loss	0	0	0	0	0%	2,764
	10,590,599	10,575,568	9,601,022	989,577	(9%)	12,522,195
Expenditure from Operating Activities						
Employee costs	(2,978,365)	(4,175,838)	(2,866,450)	(111,915)	(4%)	(4,191,693)
Materials and contracts	(3,656,465)	(4,577,336)	(3,409,280)	(247,185)	(7%)	(4,068,860)
Utility charges	(402,996)	(437,903)	(303,500)	(99,496)	(25%)	(447,625)
Depreciation	2,643	(4,436,148)	(2,957,460)	2,960,103	0%	(3,542,172)
Finance costs	(73,674)	(144,447)	(96,360)	22,686	31%	(165,717)
Insurance	(443,893)	(448,380)	(340,043)	(103,850)	(23%)	(381,835)
Other expenditure	(178,848)	(264,593)	(202,440)	23,592	13%	(266,734)
Loss on asset disposals	0	0	0	0	0%	(182,240)
	(7,731,597)	(14,484,645)	(10,175,533)	2,443,936	32%	(13,246,875)
Non-cash amounts excluded from operating activities	0	4,436,148	(2,957,460)	2,957,460	0%	3,642,371
Amount attributable to operating activities	2,859,002	527,071	(3,531,971)	6,390,973	(224%)	2,917,691
Cash Flows from Investing Activities						
Non Operating Grants, subsidies and contributions	974,615	3,268,721	2,396,760	(1,422,145)	146%	2,523,972
Proceeds from disposal of Assets	60,094	165,000	123,750	(63,656)	106%	394,293
	1,034,708	3,433,721	2,520,510	(1,485,802)	144%	2,918,265
Outflows from investing activities						
Payments for Property, Plant and equipment	(172,023)	(231,950)	(173,963)	1,940	1%	(356,766)
Payments for Land and Buildings	(17,226)	(291,000)	(218,250)	201,024	1167%	0
Payment for construction/purchase of Infrastructure	(2,387,148)	(5,566,722)	(4,175,042)	1,787,894	75%	(3,609,711)
	(2,576,396)	(6,089,672)	(4,567,254)	1,990,858	77%	(3,966,477)
Amount attributable to investing activities	(1,541,688)	(2,655,951)	(2,046,744)	505,056	33%	(1,048,212)
FINANCING ACTIVITIES						
Inflows from financing activities						
Transfer from Reserves	0	91,440	68,580	(68,580)	0%	20,000
	0	91,440	68,580	(68,580)	0%	20,000
Outflows from financing activities						
Principal elements of finance lease payments - separate from Capex	(182,080)	(237,528)	(178,146)	(3,934)	(2%)	(139,662)
Repayment of Borrowings	(163,075)	(329,051)	(246,789)	83,714	51%	(317,686)
Transfer to Reserves	0	(345,000)	(258,750)	258,750	0%	(699,665)
	(345,155)	(911,579)	(683,685)	338,529	98%	(1,157,013)
Amount attributable to financing activities	(345,155)	(820,139)	(615,105)	269,949	78%	(1,137,013)
MOVEMENT IN SURPLUS OR DEFICIT						
Surplus or deficit at the start of the financial year	3,716,584	3,716,583	2,787,437	929,146	(25%)	2,984,118
Amount attributable to operating activities	2,859,002	527,071	(2,648,978)	5,507,980	(193%)	2,917,690
Amount attributable to investing activities	(1,541,688)	(2,655,951)	(1,535,058)	(6,630)	(0%)	(1,048,212)
Amount attributable to financing activities	(345,155)	(820,139)	(461,328)	116,173	0%	(1,137,013)
Net current assets at end of financial year - surplus/(deficit)	4,688,742	767,564	(1,857,927)	6,546,670	(140%)	3,716,584

This statement is to be read in conjunction with the accompanying notes.

SHIRE OF TOODYAY
STATEMENT OF FINANCIAL POSITION
AS AT 31 MARCH 2024

	2024	2023
	\$	\$
CURRENT ASSETS		
Cash and cash equivalents	2,114,153	3,154,372
Trade and other receivables	3,480,603	1,663,193
Other financial assets	2,540,069	2,463,541
Inventories	215,098	178,620
Other assets	409,020	409,020
TOTAL CURRENT ASSETS	8,758,944	7,868,746
NON-CURRENT ASSETS		
Trade and other receivables	284,426	342,861
Other financial assets	61,117	61,117
Property, plant and equipment	40,361,789	40,361,789
Infrastructure	156,642,214	156,642,214
Right-of-use assets	144,447	144,447
TOTAL NON-CURRENT ASSETS	197,493,993	197,552,428
TOTAL ASSETS	206,252,937	205,421,174
CURRENT LIABILITIES		
Trade and other payables	1,169,304	645,016
Other liabilities	612,441	612,441
Lease liabilities	135,428	135,428
Borrowings	329,051	329,051
Employee related provisions	497,253	687,283
TOTAL CURRENT LIABILITIES	2,743,477	2,409,219
NON-CURRENT LIABILITIES		
Lease liabilities	14,070	14,070
Borrowings	4,780,858	4,943,933
Employee related provisions	87,740	87,740
TOTAL NON-CURRENT LIABILITIES	4,882,668	5,045,743

TOTAL LIABILITIES	7,626,145	7,454,962
NET ASSETS	198,626,792	197,966,212
EQUITY		
Retained surplus	(72,400,739)	(71,816,688)
Reserve accounts	(2,540,069)	(2,463,541)
Revaluation surplus	(123,685,983)	(123,685,983)
TOTAL EQUITY	(198,626,792)	(197,966,212)

This statement is to be read in conjunction with the accompanying notes.

**SHIRE OF TOODYAY
MONTHLY FINANCIAL REPORT
FOR THE PERIOD ENDED 31 MARCH 2024
PREPARATION TIMING AND REVIEW**

Prepared by: Finance Coordinator

Reviewed by: Acting Chief Executive Officer

BASIS OF PREPARATION

This prescribed financial report has been prepared in accordance with the Local Government Act 1995 and accompanying regulations Local Government Act 1995 requirements

Section 6.4(2) of the Local Government Act 1995 read with the Local Government (Financial Management) Regulations 1996 prescribe that the financial report be prepared in accordance with the Local Government Act 1995 and, to the extent that they are not inconsistent with the Act, the Australian Accounting Standards. The Australian Accounting Standards (as they apply to local governments and not-for-profit entities) and Interpretations of the Australian Accounting Standards Board were applied where no inconsistencies exist.

The Local Government (Financial Management) Regulations 1996 specify that vested land is a right-of-use asset to be measured at cost, and is considered a zero cost concessionary lease. All right-of-use assets under zero cost concessionary leases are measured at zero cost rather than at fair value, except for vested improvements on concessionary land leases such as roads, buildings or other infrastructure which continue to be reported at fair value, as opposed to the vested land which is measured at zero cost. The measurement of vested improvements at fair value is a departure from AASB 16 which would have required the Shire to measure any vested improvements at zero cost.

Local Government (Financial Management) Regulations 1996 regulation 34 prescribes contents of the financial report. Supporting information does not form part of the financial report.

Accounting policies which have been adopted in the preparation of this financial report have been consistently applied unless stated otherwise. Except for cash flow and rate setting information, the financial report has been prepared on the accrual basis and is based on historical costs, modified, where applicable, by the measurement at fair value of selected non-current assets, financial assets and liabilities.

Composition of estimated net current assets

THE LOCAL GOVERNMENT REPORTING ENTITY

functions have been included in the financial statements forming part of this financial report.

All monies held in the Trust Fund are excluded from the financial statements. A separate statement of those monies appears at Note 15 to these financial statements

Judgements and estimates

The preparation of a financial report in conformity with Australian Accounting Standards requires management to make judgements estimates and assumptions that effect the application of policies and reported amounts of assets and liabilities, income and expenses

The estimates and associated assumptions are based on historical experience and various other factors believed to be reasonable under the circumstances; the results of which form the basis of making the judgements about carrying values of assets and liabilities that are not readily apparent from other sources. Actual results may differ from these estimates

The balances, transactions and disclosures impacted by accounting estimates are as follows

- estimated fair value of certain financial assets
- impairment of financial assets
- estimation of fair values of land and buildings, infrastructure and investment property
- estimation uncertainties made in relation to lease accounting
- estimated useful life of intangible assets

SIGNIFICANT ACCOUNTING POLICES

Significant accounting policies utilised in the preparation of these statements are as described within the 2023-24 Annual Budget. Please refer to the adopted budget document for details of these policies.

SHIRE OF TOODYAY
NET CURRENT ASSET REPORT
FOR THE PERIOD ENDED 31 MARCH 2024

	Last Years Closing 30/06/2023	This Time last Year 31/03/2023	Year to Date Actual 31/03/2024
	\$	\$	\$
Composition of estimated net current assets			
Current assets			
Cash and Cash Equivalent	3,154,372	3,943,600	2,114,153
Cash Restricted-Reserves	2,463,541	1,797,548	2,540,069
Cash Restricted -Term Deposits	1,212,267	1,180,136	1,212,267
Cash Restricted - Trust	163,226	163,226	163,226
Trade and other receivables	1,663,193	2,083,876	3,300,394
Other assets	409,020	157,705	180,209
Inventories	178,620	152,931	215,098
	9,244,240	9,479,021	9,725,417
Less: current liabilities			
Trade and other payables	(645,016)	(1,180,154)	(1,169,304)
Lease liabilities	(135,428)	(139,662)	(135,428)
Long term borrowings	(329,051)	(317,686)	(329,051)
Employee provisions	(687,283)	(571,142)	(497,253)
	(1,796,778)	(2,208,644)	(2,131,036)
Net current assets	7,447,462	7,270,377	7,594,381
Less: Total adjustments to net current assets	(1,751,370)	(1,092,508)	(1,778,160)
	(3,548,148)	(3,301,152)	(3,909,196)
Net current assets used in the Statement of Financial Activity			
Non-cash amounts excluded from operating activities			
The following non-cash revenue or expenditure has been excluded from amounts attributable to operating activities within the Statement of Financial Activity in accordance with <i>Financial Management Regulation 32</i> .	Last Years Closing 30/06/2023	This Time last Year 31/03/2023	Year to Date Actual 31/03/2024
	\$		\$
Adjustments to operating activities			
Add: Loss on asset disposals	182,240	107,444	0
Add: Depreciation	3,542,172	2,461,030	2,643
Movement in current employee provisions associated with restricted cash	(31,004)	(25,263)	(31,004)
Non-cash movements in non-current assets and liabilities:			
- Pensioner deferred rates	342,861	284,871	284,426
	4,036,269	2,828,082	256,066

17

Adjustments to net current assets			
	(2,463,541)	(1,797,548)	(2,540,069)
Add: Current liabilities not expected to be cleared at end of year			
- Current portion of borrowings	329,051	317,686	329,051
- Current portion of lease liabilities	135,428	139,662	135,428
- Current portion of employee benefit provisions held in reserve	247,692	247,692	297,430
Total adjustments to net current assets	(1,751,370)	(1,092,508)	(1,778,160)

SHIRE OF TOODYAY**VARIANCE REPORT****FOR THE PERIOD ENDED 31 MARCH 2024**

The material variance thresholds are adopted annually by Council as an indicator of whether

the actual expenditure or revenue varies from the

the material variance adopted by Council for the current year is an Actual Variance

exceeding 10% and a value greater than \$5,000.

Reporting Nature and Type

Explanation of Variance	YTD BUDGET	YTD ACTUALS	VAR TO YTD BUDGET	VAR TO YTD BUDGET
Revenue			\$	%
Rates	7,584,920	7,597,115	12,195	0.16%
There is no variance to report, however, rates revenue is over budget by \$12,195 due to instalment interest.				
Fees and charges The favourable variance of Fees and Charges by \$178,416 is mainly due to (\$881,526) Waste collection fees, and Bins charges raised, rental/lease properties income of \$126,843 and other accumulative income from various income sources such as Rates search/certificate fees levy and building application fees	1,297,820	1,476,236	178,416	13.75%
Operating grants, subsidies and contributions Favourable variance is mainly attributable to DFES Grant of \$107,413, RRG(WBN) Direct Grant for 2023/2024 for \$173,727, CRC Grants for \$149,993, MAF grant received for \$191,377 and ESL grants of \$296,369 received.	363,650	1,091,778	728,128	200.23%
Interest earnings The favourable variance is mainly due to higher rates penalty interest earnings and higher interest income received on investments.	113,730	172,932	59,202	52.05%
Other Revenue A favourable variance is mainly due to Christmas Party 2023 Sponsorship donations received at CRC and standpipe water usage higher than anticipated.	240,902	252,538	11,636	4.83%
	YTD BUDGET	YTD ACTUALS	VAR TO YTD BUDGET	VAR TO YTD BUDGET
Expenses			\$	%
Employee costs Permanent /Timing variances relating to employment costs as a result of payroll costing allocations.	(2,866,450)	(2,978,365)	(111,915)	3.90%
Materials and contracts The unfavourable variance is mainly due to cost allocations of Plant and equipment and maintenance costs. A journal of \$182,081 for finance leasing, is yet to be posted to Finance costs due to misposting	(3,409,280)	(3,656,465)	(247,185)	7.25%
Utility charges The unfavourable variance is mainly due standpipe water charges at Northam-Toodyay Road	(303,500)	(402,996)	(99,496)	32.78%

	YTD BUDGET	YTD ACTUALS	VAR TO YTD BUDGET	VAR TO YTD BUDGET
Expenses			\$	%
Depreciation on non-current assets YTD depreciation for assets not raised due to Financials for June 2023 not yet been finalised. Depreciation is non-cash and does not affect net surplus	(2,957,460)	2,643	2,960,103	-100.09%
Interest expenses The variance is mainly due to the timing issues. Second payment instalment of loan interest to be paid in May 2024	(96,360)	(73,674)	22,686	-23.54%
Insurance expenses There is unfavourable variance in Insurance Expenses due to increase in premiums and non Scheme premiums(Income protection)paid to LGIS insurance.	(340,043)	(443,893)	(103,850)	30.54%
Other expenditure The variance is mainly due timing issues	(202,440)	(178,848)	23,592	-11.65%
Non-operating grants There is unfavourable variance in non-operating grants and contributions of \$1,422,145 mainly due to the timing of works on Various roads capital projects. Some Projects	2,396,760	0	(2,396,760)	-100.00%
	YTD BUDGET	YTD ACTUALS	VAR TO YTD BUDGET	VAR TO YTD BUDGET
Capital Activities				
Land and Buildings The total Capital Expenditure on Land and Building is under budget due to timing of construction work.	(218,250)	(17,226)	201,024	-92.11%
Infrastructure - Roads The total Capital Expenditure on Infrastructure Assets-Roads is under budget. This is predominantly due to timing issue with Construction work.	(3,213,812)	(1,824,448)	1,389,363	-43.23%
Infrastructure - Footpaths	(251,250)	(24,856)	226,394	-90.11%
Infrastructure - Bridges & Drainage The total Capital Expenditure on Drainage and Bridges is tracking well.	(435,005)	(323,527)	111,477	-25.63%
Infrastructure - Other The total Capital Expenditure on Infrastructure Assets- Others is tracking well.	(274,976)	(214,316)	60,660	-22.06%
Plant and Equipment Plant and equipment budget is under budget due to timing issues.	(173,963)	(172,023)	1,940	-1.11%
Loans				
Loan Repayments Principal and interest repayments for the period ending 31 March 2024 in accordance with WATC schedule.	(96,360)	(73,674)	22,686	-23.54%
Reserves				
Transfer from Reserves No transfers from reserves required as yet.	68,580	0	(68,580)	-100.00%
Transfer to Reserves No transfers to reserves required as yet.	(258,750)	0	258,750	-100.00%

SHIRE OF TOODYAY

SUPPLEMENTARY INFORMATION

FOR THE PERIOD ENDED 31 MARCH 2024

OPERATING ACTIVITIES

CASH AND FINANCIAL ASSETS

Description	Interest Rate	Unrestricted	Restricted	Trust	Total Cash	Institution	Maturity Date
		\$	\$	\$	\$		
Cash Deposits							
Municipal-Operating account		571,573.30			571,573.30	Bendigo Bank	
Municipal at Call & savers account		1,542,580.12			1,542,580.12	Bendigo Bank	
Trust-633 000 110 482 783				163,226.12	163,226.12	Bendigo Bank	
Reserve Account	0.42%		2,540,069.39		2,540,069.39	Bendigo Bank	
633 000 137 945 127	0.35%			145,931.34	145,931.34	Bendigo Bank	
633 000 152 237 145	0.35%			50,983.04	50,983.04	Bendigo Bank	
633 000 152 238 135	0.35%			128,905.24	128,905.24	Bendigo Bank	
633 000 152 238 176	0.35%			214,743.09	214,743.09	Bendigo Bank	
633 000 152 238 218	0.35%			465,568.04	465,568.04	Bendigo Bank	
633 000 152 240 834	0.35%			33,888.38	33,888.38	Bendigo Bank	
633 000 158 622 795	0.35%			25,104.38	25,104.38	Bendigo Bank	
633 000 165 467 309	0.35%			127,174.91	127,174.91	Bendigo Bank	
633 000 173 945 890	0.35%			9,748.67	9,748.67	Bendigo Bank	
633 000 184 647 550	0.35%			10,220.32	10,220.32	Bendigo Bank	
SHIRE OF TOODYAY							
Total		2,114,153.42	2,540,069.39	1,375,493.53	6,029,716.34		
Comprising							
Cash and cash equivalents		2,114,153.42	2,540,069.39	1,375,493.53	6,029,716.34		
		2,114,153.42	2,540,069.39	1,375,493.53	6,029,716.34		

KEY INFORMATION

Cash and cash equivalents include cash on hand, cash at bank, deposits available on demand with banks and other short term highly liquid investments with original maturities of three months or less that are readily convertible to known amounts of cash and which are subject to an insignificant risk of changes in value and bank overdrafts. Bank overdrafts are reported as short term borrowings in current liabilities in the statement of net current assets.

The local government classifies financial assets at amortised cost if both of the following criteria are met:

- the asset is held within a business model whose objective is to collect the contractual cashflows, and
- the contractual terms give rise to cash flows that are solely payments of principal and interest.

Financial assets at amortised cost held with registered financial institutions are listed in this note other financial assets at amortised cost are provided in Note 4 - Other assets.

**SHIRE OF TOODYAY
SUPPLEMENTARY INFORMATION**

DEBTORS ACCOUNT RECONCILIATION AS AT 31 MARCH 2024					
Description	Current	31-59 Days	60-89 Days	Over 90 Days	Balance
Debtor Control-Miscellaneous Debtors	175,304.76	529,685.74	4,420.18	13,834.57	723,245.25
Debtor Control-Infringements	0.00	182.25	0.00	0.00	182.25
Debtor Control-Community Services	998.70	381.90	123.00	943.80	2,447.40
Debtor Control-Waste Management	97.72	0.00	293.16	287.72	678.60
Cemetry Fees	0.00	0.00	0.00	1675.5	1,675.50
Dog Registration	0.00	20.00	0.00	200.00	220.00
Total	176,401.18	530,269.89	4,836.34	16,941.59	728,449.00

Account Reconciliation	
Debtors Accounts Total	728,449.00
Debtors Control Accounts Total	728,449.00
Variance	0.00

Comments/Notes-Receivable General

This aged debtors reflects Sundry debtors only. It does not include other debtors such as GST due from ATO and Pensioner Rebates due from the State

SHIRE OF TOODYAY
SUPPLEMENTARY INFORMATION

RATES ACCOUNT RECONCILIATION AS AT 31 MARCH 2024

	Current Overdue	Arrears-Year 1	Arrears-Year 2	Arrears-Year 3 and over	Deferments	Total Balance	Variance
Rates Control	1,697,239.45	291,299.74	104,260.85	112,645.24	0.00	2,205,445.28	0.00
Rates Deferment	0.00	0.00	0.00	0.00	284,426.12	284,426.12	0.00
Rates PrePayment	-173,805.43	0.00	0.00	0.00	0.00	-173,805.43	0.00
Total	1,523,434.02	291,299.74	104,260.85	112,645.24	284,426.12	2,316,065.97	0.00

Account Reconciliation

Rates Accounts Total	2,316,065.97
Rates Control Accounts Total	2,316,065.97
Variance	0.00

NOTE

Rates Control account is a summary account presenting the balances of all rates payers transactions for the period.
Deferment of the payment of Shire rates means that the pensioner does not have to pay their Council rates each year (Deferment only applies to Rates, Water Rates and Emergency Service Levy only, all other charges must be paid in full).
Rates Prepayment is when rates payers makes excess payment for their rates, resulting in the Shire owing the rates payers.

SHIRE OF TOODYAY
SUPPLEMENTARY INFORMATION
FOR THE MONTH ENDED 31 MARCH 2024
RESERVE ACCOUNTS

Reserve Accounts - Movement

	2023/24	2023/24	2023/24	2023/24	2023/24	2023/24	2023/24	2022/23	2022/23	2022/23	2022/23	
	Actual	2023/24	Actual	Actual	Budget	2023/24	Budget	Budget	Actual	2022/23	Actual	Actual
	Opening	Actual	Transfer	Closing	Opening	Budget	Transfer	Closing	Opening	Actual	Transfer	Closing
	Balance	Transfer to	(from)	Balance	Balance	Transfer to	(from)	Balance	Balance	Transfer to	(from)	Balance
	\$	\$	\$	\$	\$	\$	\$	\$	\$	\$	\$	\$
Restricted by council												
(a) Employee Entitlement Reserve	278,697	8,658	0	287,355	272,430	0	0	272,430	247,692	31,005	0	278,697
(b) Asset Development Reserve	612,919	19,041	0	631,959	604,608	0	(145,000)	459,608	328,417	284,502	0	612,919
(c) CCTV Reserve	27,802	863	0	28,665	27,116	0	0	27,116	27,144	658	0	27,802
(d) Emergency Management Reserve Newcastle Footbridge & Pedestrian Overpass Reserve	77,258	2,400	0	79,658	75,350	0	0	75,350	75,429	1,829	0	77,258
(e) Reserve	44,470	1,381	0	45,852	43,494	0	0	43,494	38,536	5,934	0	44,470
(f) Heritage Reserve	11,449	356	0	11,805	11,166	0	(10,000)	1,166	11,178	271	0	11,449
(g) Plant Reserve	155,855	4,841	0	160,696	152,005	0	0	152,005	152,166	3,689	0	155,855
(h) Recreation Development Reserve	261,628	8,126	0	269,754	255,411	10,000	0	265,411	245,672	15,956	0	261,628
(i) Refuse Reserve	118,301	3,675	0	121,976	115,379	0	0	115,379	115,501	2,800	0	118,301
(j) Road Contribution Reserve	381,346	11,847	0	393,193	376,345	150,000	(50,000)	476,345	197,676	203,670	(20,000)	381,346
(k) Strategic Access & Egress Reserve	340,255	10,570	0	350,825	334,319	50,000	(156,440)	227,879	234,568	105,687	0	340,255
(l) Drainage and Sewerage Reserve	132,561	4,117	0	136,678	129,780	20,000	0	149,780	109,897	22,664	0	132,561
(m) Biosecurity Reserve	1,000	31	0	1,031	1,000	5,000	0	6,000	0	1,000	0	1,000
(n) Roads Reserve	20,000	622	0	20,622	20,000	25,000	0	45,000	0	20,000	0	20,000
(o) Buildings Reserve	0	0	0	0	0	5,000	0	5,000	0	0	0	0
(p) Plus interest to be allocated	0	0	0	0	0	80,000	0	80,000	0	0	0	0
	2,463,540	76,529.02	0	2,540,069.39	2,418,403	345,000	(361,440)	2,401,963	1,783,876	699,664	(20,000)	2,463,540

(b) Reserve Accounts - Purposes

In accordance with Council resolutions in relation to each reserve account, the purpose for which the reserves are set aside are as follows:

Reserve name	Anticipated date of use	Purpose of the reserve
(a) Employee Entitlement Reserve	Ongoing	Funds set aside to provide payments for Employee Entitlement liabilities
(b) Asset Development Reserve	Ongoing	Funds set aside for the future purchase and/or development of assets
(c) CCTV Reserve	Ongoing	Funds set aside for the replacement, expansion and maintenance of CCTV
(d) Emergency Management Reserve	Ongoing	Funds set aside to assist in emergency management and recovery
(e) Newcastle Footbridge & Pedestrian Overpass Reserve	Ongoing	Funds set aside for the maintenance and upkeep of the Newcastle Footbridge and the Duke Street Pedestrian Overpass
(f) Heritage Reserve	Ongoing	Funds set aside for the preservation and/or purchase of Built Heritage assets of significance within the Shire of Toodyay
(g) Plant Reserve	Ongoing	Funds set aside for the ongoing upgrade and replacement of Council owned fleet
(h) Recreation Development Reserve	Ongoing	Funds set aside for the development of recreational facilities
(i) Refuse Reserve	Ongoing	Funds set aside for the development and maintenance of the Shire of Toodyay Waste Transfer Station
(j) Road Contribution Reserve	Ongoing	Funds set aside from contributions given towards particular roads to assist in the ongoing maintenance and preservation of these roads. These funds cannot be used on roads other than those identified in the contribution.
(k) Strategic Access & Egress Reserve	Ongoing	Funds set aside for the implementation and maintenance of strategic access and egress tracks
(l) Drainage and Sewerage Reserve	Ongoing	Funds set aside for drainage improvements
(m) Biosecurity Reserve	Ongoing	Funds set aside for the management of invasive plants and pests
(n) Roads Reserve	Ongoing	Funds set aside for future road maintenance, renewals and upgrades
(o) Buildings Reserve	Ongoing	Funds set aside for future building maintenance, renewals and upgrades

SHIRE OF TOODYAY
 SUPPLEMENTARY INFORMATION
 FOR THE MONTH ENDED 31 MARCH 2024
 BORROWINGS

Purpose	Loan		Interest Rate	2023/2024		Actual		2023/2024		2023/2024		Budget		2023/2024		2022/2023		2022/2023		Actual		2022/2023	
	Number	Institution		Principal	New	Principal	outstanding	Interest	Principal	New	Principal	outstanding	Interest	Principal	New	Principal	outstanding	Principal	outstanding	Interest	Principal	outstanding	Interest
Loan 67 - Library Upgrade	67	WATC	6.6%	50,504	\$ 0	\$ (24,842)	\$ 25,662	\$ (1,667)	\$ 97,833	\$ 0	\$ (50,504)	\$ 47,329	\$ (2,513)	\$ 97,833	\$ 0	\$ (47,329)	\$ 50,504	\$ 5,689					
Loan 72 - Land - Rec Precinct	72	WATC	4.5%	608,288	0	(24,479)	583,809	(13,534)	655,659	0	(49,503)	606,156	(26,524)	655,659	0	(47,371)	608,288	28,656					
Loan 75B - Recreation Precinct	75B	WATC	2.31%	4,137,043	0	(93,369)	4,043,674	(47,690)	4,320,601	0	(187,815)	4,132,787	(94,303)	4,320,601	0	(183,558)	4,137,043	98,560					
Loan 71 - Depot - Stage 2	71	WATC	4.52%	477,150	0	(20,384)	456,766	(10,784)	516,577	0	(41,230)	475,347	(21,106)	516,578	0	(39,427)	477,150	22,909					
				5,272,985	0	(163,075)	5,109,910	(73,674)	5,590,671	0	(329,052)	5,261,619	(144,446)	5,590,671	0	(317,686)	5,272,985	155,813					

SHIRE OF TOODYAY
 SUPPLEMENTARY INFORMATION
 FOR THE MONTH ENDED 31 MARCH 2024

LEASE LIABILITIES

Purpose	Institution	Lease Interest Rate	Lease Term	2023/24 Actual		2023/24 Actual		2023/24 Budget		2022/23 Actual		2022/23 Actual		
				Principal	Lease	Principal	Lease	Principal	Lease	Principal	Lease	Principal	Lease	
				2023	30 June 2024	30 June 2024	30 June 2024	1 July 2023	30 June 2024	1 July 2022	30 June 2023	30 June 2023	30 June 2023	30 June 2023
ESRI Mapping Software	Commonwealth Bank	1.70%	36 months	\$ 0	\$ (2,047)	\$ (2,047)	\$ 0	\$ 0	\$ 0	\$ 8,673	\$ (8,673)	\$ 0	\$ (895)	
Drum Roller	Gear Select	1.50%	60 months	42,208	(18,793)	23,415	0	42,208	(25,056)	17,152	67,060	(24,852)	42,208	(2,311)
IVECO Truck	CNHI Capital	4.30%	60 months	0	(26,245)	(26,245)	0	0	(50,000)	(50,000)	23,747	(23,747)	0	(1,628)
Front Wheel Loader	Komatsu	1.50%	60 months	87,758	(40,102)	47,656	0	87,758	(53,472)	34,286	137,162	(49,404)	87,758	(1,581)
Grader	Komatsu	2.10%	60 months	0	(37,317)	(37,317)	0	0	(59,000)	(59,000)	28,037	(28,037)	0	(2,965)
Photocopier	WOBM	2.10%	60 months	1	0	1	0	0	0	0	1	0	1	(119)
Solar Proposal Library/Depot	All Leasing	2.20%	84 months	5,462	(1,791)	3,671	0	5,462	0	5,462	10,411	(4,949)	5,462	(405)
Hino 700 Series Tip Truck T0010				0	(55,785)	(55,785)	0	0	(50,000)	(50,000)	0	0	0	0
				135,429	(182,080)	(46,651)	0	135,428	(237,528)	(102,100)	275,091	(139,662)	135,429	(9,904)

MATERIAL ACCOUNTING POLICIES
 LEASES

At the inception of a contract, the Shire assesses whether the contract is, or contains, a lease. A contract is, or contains, a lease if the contract conveys the right to control the use of an identified asset for a period of time in exchange for consideration. At the commencement date, a right-of-use asset is recognised at cost and a lease liability at the present value of the lease payments that are not paid at that date. The lease payments are discounted using the interest rate implicit in the lease, if that rate can be readily determined. If that rate cannot be readily determined, the Shire uses its incremental borrowing rate.

LEASE LIABILITIES

The present value of future lease payments not paid at the reporting date discounted using the incremental borrowing rate where the implicit interest rate in the lease is not readily determined.

SHIRE OF TOODYAY**SUPPLEMENTARY INFORMATION**

FOR THE PERIOD ENDED 31 MARCH 2024

CAPITAL ACQUISITIONS	CAPITAL ACQUISITION			
	Adopted Revised	YTD Budget	YTD Actual Total	(Under)/Over (F)-(E)
	\$	\$	\$	\$
Land and Buildings	(291,000)	(218,250)	(17,226)	(201,024)
Plant and Equipment	(231,950)	(173,963)	(172,023)	(1,940)
Infrastructure Assets - Roads	(4,285,082)	(3,213,812)	(1,824,448)	(1,389,363)
Infrastructure Assets - Footpaths	(335,000)	(251,250)	(24,856)	(226,394)
Infrastructure Assets - Drainage & Bridges	(580,006)	(435,005)	(323,527)	(111,477)
Infrastructure Assets - Other	(366,634)	(274,976)	(214,316)	(60,660)
	(6,089,672)	(4,567,254)	(2,576,396)	(1,990,858)

SIGNIFICANT ACCOUNTING POLICIES

Each class of fixed assets within either plant and equipment or infrastructure, is carried at cost or fair value as indicated less,

where applicable, any accumulated depreciation and impairment losses

Assets for which the fair value as at the date of acquisition is under \$5,000 are not recognised as an asset in accordance with

Financial Management Regulation 17A (5) . These assets are expensed immediately.

Where multiple individual low value assets are purchased together as part of a larger asset or collectively forming a larger asset exceeding the threshold, the individual assets are recognised as one asset and capitalised.

Initial recognition and measurement for assets held at cost
Plant and equipment including furniture and equipment is recognised at cost on acquisition in accordance with Financial Management Regulation 17A. Where acquired at no cost the asset is initially recognise at fair value. Assets held at cost are depreciated and assessed for impairment annually.

Initial recognition and measurement between mandatory revaluation dates for assets held at fair value

In relation to this initial measurement, cost is determined as the fair value of the assets given as consideration plus costs incidental to the acquisition. For assets acquired at zero cost or otherwise significantly less than fair value, cost is determined as fair value at the date of acquisition. The cost of non-current assets constructed by the Shire includes the cost of all materials used in construction,

SHIRE OF TOODYAY

SUPPLEMENTARY INFORMATION

FOR THE PERIOD ENDED 31 MARCH 2024

CAPITAL ACQUISITIONS

	2023/24 Adopted Budget	Mid Year Budget Review	CARRY FORWARDS 2024/2025	YTD Actual Total
	\$	\$		\$
LAND AND BUILDINGS	501,539	291,000	410,539	17,226
Non-Crown Land Mitigation	275,539	0	275,539	0
Bejoording Fire Station	135,000	0	135,000	0
Butterly House - Veranda Repairs	10,000	10,000	0	0
Butterly House - Replacement of Front Fence	0	0	0	9,044
Morangup Hall - Commercial Kitchen and Floor Sealing	5,000	5,000	0	0
Donegans Cottage - Structural Repair	30,000	30,000	0	0
Library Drainage & Brickwork Repair and Painting	25,000	25,000	0	0
Parkers Cottage - Structural Repair	6,000	6,000	0	0
Clinton Street Duplex - Seal Roof	10,000	10,000	0	8,182
Visitors Centre - Security/Duress Alarms	5,000	5,000	0	0
Racecourse Buildings	0	200,000	0	0
PLANT AND EQUIPMENT	766,034	231,950	654,769	172,023
HEAVY VEHICLE/PLANT REPLACEMENT SCHEDULE	716,769	132,000	654,769	16,936
John Deere 670GP	400,000	70,000	400,000	0
Side Tip Trailer - 1	100,000	0	100,000	16,936
Cherry Picker	55,000	55,000	0	0
Skid Steer Broom	7,000	7,000	0	0
Evac Centre Generator	154,769	0	154,769	0
LIGHT VEHICLE REPLACEMENT SCHEDULE	49,265	99,950	0	155,087
Isuzu MUX - T0000	49,265	49,265	0	49,755
Isuzu D-Max Space Cab Chassis-T0001	0	50,685	0	50,685
New Isuzu D-Max 4x4 Dual Cab utility-T0023	0	0	0	54,647
INFRASTRUCTURE	5,486,923	5,566,722	312,879	2,387,148
ROADS	4,403,977	4,285,082	312,879	1,824,448
Bejoording Road - Widening - SLK 9.34 - 12.30	50,000	50,000	0	0
Telegraph Rd - Bindi Bindi Toodyay Road(From Connor St)SLK 0.00-3.00 -30000189(Federal Black Sport Funding)	0	0	0	3,850
Bindi Bindi Toodyay Road - SLK 2.86 - 6.56 - Wheel Path Pavement Repairs	180,000	230,000	0	0
Bindi Bindi Toodyay Road - Reseal & Linemarking - SLK 11.08 - 13.45	229,976	229,976	0	3,324
Julimar Road Rehabilitation - RRG - SLK 17.56 - 19.81(Regional Roads group)	649,746	649,746	0	617,073
Julimar Road Rehabilitation -RRG Black Spot - SLK 14.11 - 15.96(Regional Roads group)	1,031,716	1,031,716	0	503,519
Chitty Road Upgrade - R2R SLK 4.34 - 6.75(Roads to Recovery)	180,000	180,000	0	218,640
Julimar Road Edge Break Repairs-Council Funded	0	143,984		147,760
Julimar Road - RRG-SLK 19.81 - 22.52 (Regional Roads Groups)	819,759	819,759	0	259,528
Clackline Toodyay Road - Reseal & Linemarking -SLK 5.55- SLK 10.55	473,500	473,500	0	754
Asphalt Repairs - Hamersley, Clinton, Fiennes & Anzac	73,650	73,650	0	0
Maintenance of Roadside Vegetation - Contract Works	70,000	70,000	0	70,000

WSFN Project Development - Bindoon Dewars Pool Road	180,000	180,000	0	0
Nottingham Road - Section 2 - SLK 0.29 - 0.50	166,976	0	166,976	0
Budget for significant edgebreaks - profiling	152,751	152,751	0	0
North Street - Road Upgrade - SLK 0.44 - 0.60	145,903	0	145,903	0
BRIDGES	580,006	580,006	0	323,527
Bridge No. 0698 - Bindi Bindi Toodyay Road - Picnic Hill - Bridge Repair	20,000	20,000	0	0
Bridge No. 0697 - Bindi Bindi Toodyay Road - Waters Brook - Bridge Repairs	20,000	20,000	0	0
Bridge No. 4080 - Julimar Road - West Toodyay	181,836	181,836	0	170,407
Bridge No. 4085 - Slaughterhouse Bridge	79,123	79,123	0	71,930
Bridge No. 0702 - Bindi Bindi Toodyay Road - Connor Road	17,000	17,000	0	0
Bridge No. 0708 - Bindoon Dewars Pool Road	20,000	20,000	0	10,750
Bridge No. 4085 - Slaughterhouse Bridge - MRWA Design	90,000	90,000	0	0
Bridge No. 9025 - Newcastle Pedestrian Footbridge - Pile Replacement	93,445	93,445	0	12,000
Bridge No. 4084 - Dumbarton Bridge	58,602	58,602	0	58,440
FOOTPATHS	335,000	335,000	0	24,856
Stirling Terrace & Goomalling Toodyay Road Kerb & Pram Ramp replacement	15,000	15,000	0	18,810
Townsite - Heavy Haulage - Footpath Corrective Action	40,000	40,000	0	4,651
Toodyay Street - Shared Pathway	98,000	98,000	0	0
Jubilee Street - Shared Pathway	182,000	182,000	0	1,396
OTHER INFRASTRUCTURE	167,940	366,634	0	214,316
Fire Water tanks various (DFES funded 21/22 c/fwd)	24,340	24,340	0	14,443
Installation of Water Tanks - Recreation Centre	105,600	105,600	0	0
Charcoal Lane Lighting	20,000	20,000	0	17,923
Depot Material Bunkers	8,000	8,000	0	0
Newcastle Park - Upgrade	0	179,694	0	179,694
Community Standpipe Shade structure	10,000	10,000	0	1,128
Timber Deck required for the Pool	0	19,000	0	1,128
TOTAL CAPITAL EXPENDITURE	6,754,496	6,089,672	1,378,187	2,576,396

SIGNIFICANT ACCOUNTING POLICIES

All assets are initially recognised at cost. Cost is determined as the fair value of the assets given as consideration plus costs incidental to the acquisition. For assets acquired at no cost or for nominal consideration, cost is determined as fair value at the date of acquisition. The cost of non-current assets constructed by the local government includes the cost of all materials used in the construction, direct labour on the project and an appropriate proportion of variable and fixed overhead. Certain asset classes may be revalued on a regular basis such that the carrying values are not materially different from fair value. Assets carried at fair value are to be revalued with sufficient regularity to ensure the carrying amount does not differ materially from that determined using fair value at reporting date.

**SHIRE OF TOODYAY
SUPPLEMENTARY INFORMATION
FOR THE MONTH ENDED 31 MARCH 2024
FIXED ASSETS**

The following assets are budgeted to be acquired and/or disposed of during the year.

	2023/24 Actual Additions	2023/24 Disposals - Net Book Value	2023/234 Actual Disposals - Sale Proceeds	2023/24 Actual Disposals - Profit or Loss	2023/24 Budget Additions	2023/24 Budget Disposals - Net Book Value	2023/24 Budget Disposals - Sale Proceeds	2022/23 Actual Additions	2022/23 Disposals - Net Book Value	2022/23 Actual Disposals - Sale Proceeds	2022/23 Actual Disposals - Profit or Loss
	\$	\$	\$	\$	\$	\$	\$	\$	\$	\$	\$
(a) Property, Plant and Equipment											
Land - freehold land	0	0	0	0	275,539	0	0	0	368,080	276,540	(91,540)
Buildings - non-specialised	0	0	0	0	226,000	0	0	0	0	0	0
Buildings - specialised	17,226	0	0	0	0	0	0	0	0	0	0
Furniture and equipment	0	0	0	0	0	0	0	24,894	0	0	0
Plant and equipment	0	0	0	0	766,034	240,000	240,000		277,393	117,752	(159,641)
Total	17,226	0	0	0	1,267,573	240,000	240,000	24,894	645,473	394,292	(251,181)
(b) Infrastructure											
Infrastructure - roads	1,824,448	0	0	0	4,403,977	0	0	3,603,407	0	0	0
Other infrastructure Bridges	323,527	0	0	0	580,006	0	0	0	0	0	0
Other infrastructure Drainage	0	0	0	0	0	0	0	0	0	0	0
Other infrastructure Footpaths	24,856	0	0	0	335,000	0	0	0	0	0	0
Other infrastructure	214,316	0	0	0	167,940	0	0	0	0	0	0
Total	2,387,148	0	0	0	5,486,923	0	0	3,603,407	0	0	0
(c) Right of Use Assets											
Right of use - plant and equipment	172,023	0	0	0	237,528	0	0	0	0	0	0
Total	0	0	0	0	237,528	0	0	0	0	0	0
Total	172,023	0	0	0	475,056	0	0	0	0	0	0

**MATERIAL ACCOUNTING POLICIES
RECOGNITION OF ASSETS**

Assets for which the fair value as at the date of acquisition is under \$5,000 are not recognised as an asset in accordance with Financial Management Regulation 17A (5). These assets are expensed immediately.

Where multiple individual low value assets are purchased together as part of a larger asset or collectively forming a larger asset exceeding the threshold, the individual assets are recognised as one asset and capitalised.

GAINS AND LOSSES ON DISPOSAL

Gains and losses on disposals are determined by comparing proceeds with the carrying amount. These gains and losses are included in profit or loss in the period which they arise.



MID YEAR BUDGET REVIEW 2023/24
SUMMARY OF PROPOSED BUDGET AMENDMENTS

Amendments to original budget since budget adoption. Surplus/(Deficit)

GL Account Code	Description	Comments	Adopted Budget	Proposed Budget	Increase in Available Cash	Decrease in Available Cash	Amended Budget Running Balance
	Budget Adoption 28 August 2023	Opening surplus -	4,710		\$	\$	\$ 4,710
	Net current assets at end of Financial Year 2023	Net current assets at end of financial year - surplus	599,583				599,583
031.010.10	Rates - Gross Rental Value	Higher interim rates on gross rental values than projected	(4,500,690)	(4,510,331)	9,641	0	613,934
031.015.10	Rates - Unimproved Value	Higher interim rates on unimproved values than projected	(3,092,170)	(3,094,452)	2,282	0	616,216
031.100.10	Rates Search / Certificate Fee	Increased property search and rates information requests than projected.	(20,000)	(28,456)	8,456	0	624,672
031.151.10	Rates- Interest Penalty	Interest raised on outstanding rates higher than projected.	(70,000)	(76,000)	6,000	0	630,672
032.157.10	Interest on investments	Interest earned on investments higher than expected.	(95,000)	(144,000)	49,000	0	679,672
041.447.10	Members of Council - Other Materials and Contracts	Contribution to AROC initiated shared project-Regional housing strategy.	1,500	10,000	0	(8,500)	671,172
043.300.10	Office of the CEO - Salaries & Wages	Additional funds required for engagement of temporary CEO	380,830	410,830	0	(30,000)	641,172
043.339.10	Professional Services - Consultants, Survey, Design and Audits	Additional funds required for recruitment of new CEO	72,090	92,090	0	(20,000)	621,172
044.393.10	Corporate Services - Computer Software and Licences	Funds required for purchase and implementation of records management system.	221,762	317,920	0	(96,158)	525,014
044.414.10	Corporate Services - Public Liability Insurance	Insurance premiums increased higher than budget projections.	47,065	54,835	0	(7,770)	517,244
053.300.10	Salaries & Wages	Additional funds required for recruitment due to recent staff resignations and payout of leave.	152,109	190,000	0	(37,891)	479,353
054.420.10	Emergency Management - Motor Vehicle Insurance	Increased insurance premiums than projected	25,554	30,554	0	(5,000)	474,353

054.595.51	Emergency Services - Transfer from Asset Development Reserve	Bejoording Fire Station Construction has not been approved. Transfer from Reserve not required this Financial Year.	(135,000)	0	0	(135,000)	339,353
054.733.50	Emergency Management - Fixed Assets – Buildings - Specialised	Bejoording Fire Station Construction has not been approved. Application to be lodged for 2024/2025.	135,000	0	135,000	0	474,353
056.131.10	Fire and Land Management - Other Grants	Final instalment payment received (\$14,993) of MAF 2022/2023 Round 2 and First 50% instalment (\$107,500) of MAF 2023/2024	(74,380)	(122,493)	48,113	0	522,466
087.131.10	Other Welfare - Other Grants	Additional unbudgeted funds received for the CRC Regional Traineeship Program Grant 2023-2024 (\$38000) and Get online grant 2023 (\$1000).	(108,640)	(149,422)	40,782	0	563,248
087.178.10	Other Welfare - Other Income	Toodyay Christmas Street Party 2023 Sponsorship (\$5605) and various donations received.	(100)	(10,460)	10,360	0	573,608
106.336.10	Town Planning/Regional Development - Contr	Funds allocated for Gazette Project will not be spent prior to 30 June 2024.	39,950	35,000	4,950	0	578,558
107.131.10	Other Community Amenities - Other Grants	Funds for Community Centre Upgrade received; carry over from FY 2022/2023 (\$9,000).	0	(9,000)	9,000	0	587,558
113.133.50	Recreation & Sport -Evac Centre Generator	Request carry over-delay in grant agreement approval. Not expected prior to June 2024.	(77,381)	0	0	(77,381)	510,177
113.739.50	Recreation & Sport -Evac Centre Generator	Request carry over-delay in grant agreement approval. Not expected prior to June 2024.	154,769	0	154,769	0	664,946
113.595.51	Specialised Buildings - Transfer From Reserve	Additional funds allocated from reserve for Toodyay Racecourse. Renewals of roof sheeting and gutter of the building , the Tote area and Horseshoe Bar.	0	(200,000)	200,000	0	864,946
113.756.50	Racecourse Buildings	Works to be carried at Toodyay Racecourse, renewals of roof sheeting, gutter of the building, the Tote area and Horseshoe Bar.	0	200,000	0	(200,000)	664,946
113.756.50	Timber deck repairs-unbudgeted.	Unbudgeted Item: Funding for decking repairs to the pool.	105,600	124,600	0	(19,000)	645,946
116.130.10	Heritage- State Grants	Heritage Grant approved.Any unspent grant to be carried over to 2024/25 FY	(420)	(20,000)	19,580	0	665,526
116.336.10	Heritage - Contractors	Heritage Survey project -Any unspent component to be carried over to 2024/25 FY	71,320	101,320	0	(30,000)	635,526
117.438.10	Community Sponsorship - Donations Paid	Toodyay Fibre Festival (2024) cancelled this year: allocation from funding pool not required- \$8 000.00	0	(8,000)	8,000	0	643,526
121.133.50	Bejoording Road - Widening - SLK 9.34 - 12.30	Bejoording Road widening-Design was undertaken in 2022/23. Funds to be allocated to Chitty Road upgrade-R2R SLK 4.34-6.75	(50,000)	0	0	(50,000)	593,526

121.133.50	Chitty Road Upgrade - R2R SLK 4.34 - 6.75 (Roads to Recovery)	Funds to be transferred from Bejoording Road widening SLK 9.34-12.30.	(180,000)	(230,000)	50,000	0	643,526
121.741.50	Bejoording Road - Widening - SLK 9.34 - 12.30	Bejoording Road widening-Design was undertaken in 2022/23. Funds to be allocated to Chitty Road upgrade-R2R SLK 4.34-6.75	50,000	0	50,000	0	693,526
121.741.50	Chitty Road Upgrade - R2R SLK 4.34 - 6.75(Roads to Recovery)	Funds to be transferred from Bejoording Road widening SLK 9.34-12.30.	180,000	230,000	0	(50,000)	643,526
121.133.50	Bridge No. 9025 - Footbridge-Pile Replacement-Solar lighting	Funds to be transferred from bridge No.0697 and bridge No. 0968, subject to approval from LRCI	(93,445)	(113,445)	20,000	0	663,526
121.133.50	Bridge No. 0698 - Bindi Bindi Toodyay Road - Picnic Hill - Bridge Repair	Funds to be transferred to Solar lighting project, ending approval from LRCI	(20,000)	(10,000)	0	(10,000)	653,526
121.133.50	Bridge No. 0697 - Bindi Bindi Toodyay Road - Waters Brook - Bridge Repairs	Funds to be transferred to Solar lighting project, subject to approval from LRCI	(20,000)	(10,000)	0	(10,000)	643,526
121.133.50	Nottingham Road - Section 2 - SLK 0.29 - 0.51	Unsuccessful grant application. Officers to reapply in 2024/25	(83,488)	0	0	(83,488)	560,038
121.133.50	North Street - Road Upgrade - SLK 0.44 - 0.61	Unsuccessful grant application. Officers to reapply in 2024/25	(72,952)	0	0	(72,952)	487,086
121.595.51	Nottingham Road - Section 2 - SLK 0.29 - 0.50	Unsuccessful grant application this Year. Transfers from Reserves to be deferred	(83,488)	0	0	(83,488)	403,598
121.595.51	North Street - Road Upgrade - SLK 0.44 - 0.60	Unsuccessful grant application this Year. Transfers from Reserves to be deferred	(72,952)	0	0	(72,952)	330,646
121.741.50	Nottingham Road - Section 2 - SLK 0.29 - 0.51	Carry-over to FY2024/2025 due to unsuccessful grant application.	166,976	0	166,976	0	497,622
121.741.50	North Street - Road Upgrade - SLK 0.44 - 0.61	Carry-over to FY2024/2025 due to unsuccessful grant application.	145,903	0	145,903	0	643,525
121.746.10	Bridge No. 9025 - Footbridge-Pile Replacement-Solar lighting	Additional funds to be transferred from bridge No.0697 and bridge No. 0968 subject to approval by LRCI	93,445	113,445	0	(20,000)	623,525
121.746.10	Bridge No. 0698 - Bindi Bindi Toodyay Road - Picnic Hill - Bridge Repair	Funds to be transferred to Solar lighting project subject to approval from LRCI	20,000	10,000	10,000	0	633,525
121.746.10	Bridge No. 0697 - Bindi Bindi Toodyay Road - Waters Brook - Bridge Repairs	Funds to be transferred to Solar lighting project subject to approval from LRCI	20,000	10,000	10,000	0	643,525
144.420.10	Plant Operations - Motor Vehicle Insurance	Increase in Insurance premiums than projected	34,848	51,348	0	(16,500)	627,025
144.739.50	John Deere 670GP-Grader	Additional funds required to cover cost of grader acquisition due to price increase post budget approval.	400,000	470,000	0	(70,000)	557,025
144.739.50	Purchase of Side Tip Trailer - 1	Carry-over - No spend in FY2023/2024 - vehicle purchase has deferred to FY2024/2025	100,000	0	100,000	0	657,025
144.758.50	Proceeds on Sale of Assets - Plant and Equipment	Carry-over \$165,000 in proceeds from sale of plant and equipment deferred to FY2024/2025.	(240,000)	(75,000)	0	(165,000)	492,025
147.133.50	Shire Owned Land Mitigation	Due to delay in grant agreement approval. Project delivery is not expected prior to 30 June 2024.	(137,770)	(137,770)	0	0	492,025

147,731.50	Shire Owned Land Mitigation	Due to delay in grant agreement approval. Project delivery is not expected prior to 30 June 2024.	275,539	0	275,539	0	767,564
					1,534,351	(1,371,080)	767,564



Creditors Payment Run

01 March 2024 to 31 March 2024

Ref# Cheque Payments					
Payment Number	Date	Cheque Number	Creditor Name	Invoice Description	Inclusive Amount
1	07-03-2024	13038	SHIRE OF TOODYAY	Library Book purchases February 2024	1,000.00
2	14-03-2024	13039	OLD GAOL MUSEUM	Old Gaol Honorariums April 2024	400.00
3	14-03-2024	13040	SHIRE OF TOODYAY	Depot petty cash recoup February 2024	93.85
4	28-03-2024	13041	DEPARTMENT OF TRANSPORT	1TYD853 12 month vehicle registration 2024 - 2025	25.30
5	28-03-2024	13042	OLD GAOL MUSEUM	Old Gaol Honorariums March 2024	500.00
6	28-03-2024	13043	WATER CORPORATION	Water Account 9007938270 - Medical & Community Centres plus DFES - Nov -	871.70
7	28-03-2024	13043	WATER CORPORATION	Water Account - 9007935192 - Shire Offices Jan-February 2024	25.80
8	28-03-2024	13043	WATER CORPORATION	Water Account - 9007935205 - Admin Gardens - Jan - February 2024	973.71
9	28-03-2024	13043	WATER CORPORATION	Water Account 9007935635 - Pelham Res Toilets	40.14
10	28-03-2024	13043	WATER CORPORATION	Water Account 9007935002 - Tennis Courts for period December 2023 - February 2024	814.23
11	28-03-2024	13043	WATER CORPORATION	Water Account 9007933760 - Northam-Toodyay Rd, Avon Hills. FI Lot adj Lot 10	105,495.68
12	28-03-2024	13043	WATER CORPORATION	Water Account 9008751598 Waste Transfer Station Railway Rd, Toodyay for January-	357.48

Payment Number	Date	Cheque Number	Creditor Name	Invoice Description	Inclusive Amount
13	28-03-2024	13043	WATER CORPORATION	Water Account 9007931837 - Newcastle Park January - February 2024	256.91
14	28-03-2024	13043	WATER CORPORATION	Water Account 9007931909 Library Stirling Tce, January - February 2024	426.97
15	28-03-2024	13043	WATER CORPORATION	Water Account 9007931917 - Mrs O'Reillys - 100 Stirling Tce - December 2023 - February 2024	365.81
16	28-03-2024	13043	WATER CORPORATION	Water Account 9007931976 - Bank Building - December 2023 - February 2024	466.36
17	28-03-2024	13043	WATER CORPORATION	Water Account 9007932530 - 61 Telegraph Rd, Toodyay Lot 277 Res 22143 - January - February	298.17
18	28-03-2024	13043	WATER CORPORATION	Water Account 9007933496 - Donegans Cottage - December 2023 - February 2024	424.43
19	28-03-2024	13043	WATER CORPORATION	Water Account 9007933509 - Parkers Cottage - January - February 2024	110.78
20	28-03-2024	13043	WATER CORPORATION	Water Account 9007933517 - Pavilion, Showgrounds & Hockey Oval - January -	14,021.98
21	28-03-2024	13043	WATER CORPORATION	Water Account 9007933568 - Duidgee Park - December - February 2024	3,154.44
22	28-03-2024	13043	WATER CORPORATION	Water Account 9007933744 - Connors Mill / VC - January - February 2024	453.83
23	28-03-2024	13043	WATER CORPORATION	Water Account 9007933752 - Connors Cottage - January - February 2024	303.43
Cheque Total					130,881.00

Electronic Funds Transfer Payments					
Ref#	Date		Creditor Name	Invoice Description	Inclusive Amount
24	07-03-2024	EFT	ALEXANDRA JEAN HURLEY	Consignment February 2024	44.00
25	07-03-2024	EFT	ALLEVARE THE LABEL	Consignment February 2024	18.50
26	07-03-2024	EFT	AUSTRALIA POST	Postage charges + renewal of PO Box for February 2024	656.38
27	07-03-2024	EFT	AVON CONCRETE	Installation of culvert extensions at SLKs 20.26, 20.67, 21.00, 21.14, 21.82, 22.00 and 22.35	56,100.00
28	07-03-2024	EFT	BAAZ SECURITY SERVICES PTY LTD	Security Services 25.01.24 - 26.01.24	1,443.75

Electronic Funds Transfer Payments					
29	07-03-2024	EFT	BORAL CONSTRUCTION MATERIALS (BORAL RESOURCES WA LTD)	10 x 205Lt Emulsions and Drums for Road Patching	4,510.00
30	07-03-2024	EFT	CONPLANT PTY LTD	Tyre and Tube for Ammann Roller	2,316.99
31	07-03-2024	EFT	CONPLANT PTY LTD	Service Wacker Neuson roller 1000 hr	2,186.93
32	07-03-2024	EFT	CORSIGN (WA) PTY LTD	100 x Culvert Markers & 500 x Guide Posts	11,825.00
33	07-03-2024	EFT	DEPARTMENT OF FIRE & EMERGENCY SERVICES	2023/24 ESL 3rd Quarter Contribution	94,826.15
34	07-03-2024	EFT	DEPARTMENT OF MINES INDUSTRY REGULATION & SAFETY	BSL Levies November 2023 -Missing levy for building permit	61.65
35	07-03-2024	EFT	EAG ELECTRICAL AIR-CONDITIONING & GAS	Test & Tag electrical equipment at the Medical Centre	531.30
36	07-03-2024	EFT	ERIC OWEN TOLHOPF	Consignment February 2024	24.00
37	07-03-2024	EFT	FRAMES WEST	Supply material for stand pipe protective cover,.	832.76
38	07-03-2024	EFT	FRAMES WEST	Supply patio tube for stand pipe shelter.	140.00
39	07-03-2024	EFT	G FORCE CONCRETE	Concrete Apron Extension - Julimar Fire Station	6,628.00
40	07-03-2024	EFT	GLENORAN LEATHER	Consignment February 2024	45.15
41	07-03-2024	EFT	John BUTLER	Consignment January 2024	7.70
42	07-03-2024	EFT	John BUTLER	Consignment February 2024	30.80
43	07-03-2024	EFT	KIMBA DESIGN	Consignment February 2024	26.60
44	07-03-2024	EFT	Leah Imelda CARVELL	Consignment February 2024	13.00
45	07-03-2024	EFT	MICKS STIX	Consignment February 2024	34.50
46	07-03-2024	EFT	NATURAL INTENTIONS BEAUTY RANGE	Consignment February 2024	45.00
47	07-03-2024	EFT	OZTROLOGY PTY LTD	Consignment February 2024	24.00
48	07-03-2024	EFT	Paul Wesley Jones SUTTON	Reimbursement of expenses 12/12/2023	160.16

Electronic Funds Transfer Payments					
49	07-03-2024	EFT	PERTH ANIMAL EMERGENCY SERVICE PTY LTD	Car Accident - Chihuahua	2,243.55
50	07-03-2024	EFT	PUBLIC TRANSPORT AUTHORITY OF WA	TransWA ticket Sales for January 2024	397.40
51	07-03-2024	EFT	QUILTS BY ROBYN	Consignment February 2024	52.00
52	07-03-2024	EFT	STEWART & HEATON CLOTHING CO PTY LTD	BFS PPE - Name Badges (Name details will be included in email)	100.85
53	07-03-2024	EFT	STEWART & HEATON CLOTHING CO PTY LTD	J795-GLD2-TDY1 (2 x 87, 2 x 92, 4 x 97, 2 x 102, 2 x 107, 1 x 112) Clothing	3,018.02
54	07-03-2024	EFT	STEWART & HEATON CLOTHING CO PTY LTD	BFS - T-shirts Sizes (3 x L, 5 x 4XL 1 x 5XL)	297.69
55	07-03-2024	EFT	STEWART & HEATON CLOTHING CO PTY LTD	Belts, Tshirts & Trousers	2,094.25
56	07-03-2024	EFT	STEWART & HEATON CLOTHING CO PTY LTD	Name Badge - ALLAN CREUSOT MORANGUP BFB	8.40
57	07-03-2024	EFT	TAMMAR PUBLICATIONS	Consignment - January - 2024	22.00
58	07-03-2024	EFT	Tanya Michelle STUART	Consignment January 2024	7.68
59	07-03-2024	EFT	Tanya Michelle STUART	Consignment February 2024	23.09
60	07-03-2024	EFT	TOODYAY TRADERS	Key Cutting one side	31.50
61	07-03-2024	EFT	TOODYAY TRADERS	Monthly Hardware Purchases - January 2024 - \$60 max per transaction Extension Lead x 1	42.25
62	07-03-2024	EFT	TOODYAY TYRE & EXHAUST	Replacement tyres & disposal for T000 - EMIAS	682.00
63	07-03-2024	EFT	TOODYAY TYRE & EXHAUST	2 x HaliTrax 17.5R25 grader tyres for Komatsu GD655-5 grader + disposal	6,436.00
64	07-03-2024	EFT	TOODYAY TYRE & EXHAUST	2 x HaliTrax 17.5R25 grader tyres for Komatsu GD655-5 grader + disposal	3,189.00
65	07-03-2024	EFT	VANGUARD PRESS	Signs designed and printed for Information Bay (2 Businesses)	190.00
66	11-03-2024	EFT	CARRINGTON'S (WA) PTY LTD	Traffic Control - Julimar Road SLK14.11 to 15.96 - 2 man crew with E Stops	1,384.90
67	11-03-2024	EFT	CARRINGTON'S (WA) PTY LTD	Supply 5 x 2 crew for Traffic Management / Control on Julimar Road SLK 14.11 - 15.96 from	20,149.53
68	11-03-2024	EFT	CARRINGTON'S (WA) PTY LTD	Traffic Management - Julimar Road SLK 14.11 to 15.96 - Tree Stump Removal	2,486.00
69	11-03-2024	EFT	CARRINGTON'S (WA) PTY LTD	Supply 5 x 2 crew for Traffic Management / Control on Julimar Road SLK 14.11 - 15.96 from	2,501.95

Electronic Funds Transfer Payments					
70	11-03-2024	EFT	CARRINGTON'S (WA) PTY LTD	Supply 5 x 2 crew for Traffic Management / Control on Julimar Road SLK 14.11 - 15.96 from	14,541.59
71	11-03-2024	EFT	CARRINGTON'S (WA) PTY LTD	Supply 5 x 2 Crew for Traffic Management / Control on Julimar Road SLK 14.11 - 15.96 from	18,595.23
72	11-03-2024	EFT	CARRINGTON'S (WA) PTY LTD	Provide traffic management for roadworks on Julimar Rd SLK 19.81 - 22.52 from 9/1/2024 to	9,650.85
73	11-03-2024	EFT	CARRINGTON'S (WA) PTY LTD	Provide emergency traffic management control for bushfire incident in Julimar 20/12/2023 to	16,114.18
76	11-03-2024	EFT	CARRINGTON'S (WA) PTY LTD	3x2 crew for traffic control Chitty Road Asphaltting works	1,469.05
77	11-03-2024	EFT	CARRINGTON'S (WA) PTY LTD	Supply traffic management crew for footpath installation works - Jubilee Street	6,384.13
79	11-03-2024	EFT	CARRINGTON'S (WA) PTY LTD	Provide traffic management for roadworks on Julimar Rd SLK 19.81 - 22.52 from 9/1/2024 to	13,714.25
80	11-03-2024	EFT	CARRINGTON'S (WA) PTY LTD	Supply traffic management crew for footpath installation works.- Toodyay Street	9,948.95
81	11-03-2024	EFT	CARRINGTON'S (WA) PTY LTD	Supply traffic management crew for footpath installation works - Jubilee Street	4,723.13
82	11-03-2024	EFT	CARRINGTON'S (WA) PTY LTD	Supply 5 x 2 crew for Traffic Management / Control on Julimar Road SLK 14.11 - 15.96 from	3,716.63
83	11-03-2024	EFT	CARRINGTON'S (WA) PTY LTD	Supply 5 x 2 crew for Traffic Management / Control on Julimar Road SLK 14.11 - 15.96 from	6,674.25
84	11-03-2024	EFT	CARRINGTON'S (WA) PTY LTD	Supply 5 x 2 crew for Traffic Management / Control on Julimar Road SLK 14.11 - 15.96 from	14,308.94
85	11-03-2024	EFT	CARRINGTON'S (WA) PTY LTD	Provide traffic management for roadworks on Julimar Rd SLK 19.81 - 22.52 from 9/1/2024 to	1,155.00
86	11-03-2024	EFT	CARRINGTON'S (WA) PTY LTD	Supply traffic management crew for footpath installation works.- Toodyay Street	9,493.55
87	11-03-2024	EFT	CARRINGTON'S (WA) PTY LTD	Provide traffic management for roadworks on Julimar Rd SLK 19.81 - 22.52 from 9/1/2024 to	11,446.60
88	11-03-2024	EFT	CARRINGTON'S (WA) PTY LTD	Provide traffic management for roadworks on Julimar Rd SLK 19.81 - 22.52 from 9/1/2024 to	6,474.33
89	11-03-2024	EFT	CARRINGTON'S (WA) PTY LTD	Provide traffic management for roadworks on Julimar Rd SLK 19.81 - 22.52 from 9/1/2024 to	7,201.70
90	11-03-2024	EFT	CARRINGTON'S (WA) PTY LTD	Provide traffic management for roadworks on Julimar Rd SLK 19.81 - 22.52 from 9/1/2024 to	9,397.85
91	11-03-2024	EFT	CARRINGTON'S (WA) PTY LTD	Provide traffic management for roadworks on Julimar Rd SLK 19.81 - 22.52 from 9/1/2024 to	10,179.13
92	14-03-2024	EFT	AVON SKIP BINS	Depot, skip bin empty for February 2024	60.00
93	14-03-2024	EFT	AVON SKIP BINS	Memorial Hall, skip bin empty for February 2024	180.00

Electronic Funds Transfer Payments					
94	14-03-2024	EFT	BUNNINGS - MIDLAND	4 x Holman 50 x 40mm PVC Reducing Coupling - Retic repairs Duidgee Park	20.52
95	14-03-2024	EFT	CORSIGN (WA) PTY LTD	100 x TDI Brackets for Sign Installation, Blade St & Timberden Dve St blades & hazard board	643.50
96	14-03-2024	EFT	EASIFLEET	Hugo De Vos payroll salary deductions PPE 12/3/2024	498.10
97	14-03-2024	EFT	FRONTLINE FIRE & RESCUE EQUIPMENT	6 x Surname Stickers (FINDLAY, WARNER, STRINGER, LITTLE, BILSKE, SOFOULIS)	66.00
98	14-03-2024	EFT	FULTON HOGAN INDUSTRIES PTY LTD	Julimar Road SLK 14.11 - 15.96 BS - SEALING WORKS	141,630.59
99	14-03-2024	EFT	FULTON HOGAN INDUSTRIES PTY LTD	Chitty Rd Upgrade SLK 4.34-6.30 - Seal and Asphalt Works	144,757.61
100	14-03-2024	EFT	INFOCOUNCIL PTY LTD	Implementation Fee, instalment 3 due in year 3 as per contract terms	4,149.20
101	14-03-2024	EFT	KOMATSU AUSTRALIA PTY LTD	Carry out 6000 hr service on Komatsu grader.	7,306.59
102	14-03-2024	EFT	M SPESHY PTY LTD	Insurance excess on vehicle repairs. 1HBZ025	300.00
103	14-03-2024	EFT	Mark ROBERTS	Reimbursement - Pre employment medical 27.02.2024	366.50
104	14-03-2024	EFT	METROCOUNT TRAFFIC DATA SPECIALISTS	Roll rubber road tube, Centre lane flaps, battery packs & road deck spikes	1,606.00
105	14-03-2024	EFT	PROFESSIONAL PC SUPPORT PTY LTD (XL2)	Managed ITC agreement 2023 - 2024 - Auditors information requests	550.00
106	14-03-2024	EFT	PROFESSIONAL PC SUPPORT PTY LTD (XL2)	Managed ITC agreement - Backup Service Online - February 2024	11,261.43
107	14-03-2024	EFT	PROFESSIONAL PC SUPPORT PTY LTD (XL2)	Managed phone agreement February 2024	1,244.04
108	14-03-2024	EFT	PROFESSIONAL PC SUPPORT PTY LTD (XL2)	Watch guard fire box x2 Library & Depot	70.33
109	14-03-2024	EFT	PROFESSIONAL PC SUPPORT PTY LTD (XL2)	Managed ITC agreement 2023 - 2024, Monitors x 2	451.00
110	14-03-2024	EFT	Sarah Jane PARKIN	Reimbursement for worker expense - volunteer - Sarah Parkin	45.00
111	14-03-2024	EFT	SHIRE OF NORTHAM	Tipping fee for all waste apart from EWaste and recycling to be delivered to the Northam waste	22,895.22
112	14-03-2024	EFT	SHIRE OF NORTHAM	Tipping fee for all waste apart from EWaste and recycling to be delivered to the Northam waste	585.48
113	14-03-2024	EFT	STEWART & HEATON CLOTHING CO PTY LTD	Two line Name Badges - (Mahar, Arentsen)	16.81
114	14-03-2024	EFT	SYNERGY	Electricity Account 149993610	1,177.53
115	14-03-2024	EFT	TELSTRA CORPORATION LTD	Telstra mobiles and data account 2608284176	1,362.35

Electronic Funds Transfer Payments					
116	14-03-2024	EFT	TELSTRA CORPORATION LTD	Telstra mobiles and data account 2608284176	1,362.34
117	14-03-2024	EFT	TELSTRA CORPORATION LTD	Telstra mobiles and data account 2608284176 Feb 24	1,337.35
118	14-03-2024	EFT	TOODYAY HARDWARE & FARM	2 Screws HX T17	22.50
119	14-03-2024	EFT	TOODYAY IGA	Staff Amenities January 2024	2,939.55
120	14-03-2024	EFT	TOODYAY TYRE & EXHAUST	4 x 265/65 R17 Toyo Tyres, Disposal and Wheel Alignment for Ranger Vehicle	1,497.00
121	14-03-2024	EFT	TOODYAY TYRE & EXHAUST	Puncture Repair Coondle 1.4/3 x Puncture Repairs Julimar 1.4 + disposal	284.00
122	14-03-2024	EFT	TOOLMART	Supply new cordless power tools for Parks and Garden crew.	1,689.00
123	14-03-2024	EFT	TOTAL GREEN RECYCLING	Waste Transfer Station - E/Waste Recycling December 2023	841.50
124	14-03-2024	EFT	URL NETWORKS PTY LTD	URL Networks - SIP Trunks February 2024	132.04
125	14-03-2024	EFT	VAPOUR PLUMBING AND GAS	Replace leaking spout at Visitors Centre kitchen sink	170.50
126	14-03-2024	EFT	WALGA	Individual e-learning enrolments - Cr Dival	869.00
127	14-03-2024	EFT	WALGA	Role of Mayors and Presidents - Cr McKeown	434.50
128	14-03-2024	EFT	WALGA	Role of Mayors and Presidents - Cr Dival	434.50
129	14-03-2024	EFT	WALGA	Understanding Financial Reports and Budgets - Cr Dival	544.50
130	14-03-2024	EFT	WALGA	Understanding Financial Reports and Budgets - Cr Prater	544.50
131	14-03-2024	EFT	WCS CONCRETE PTY LTD	Supply and Deliver ~18m3 - Concrete for Julimar Apron	4,675.00
132	14-03-2024	EFT	WEST WIDE AUTO ELECTRICS	Repair damaged wiring on front deck mower	1,037.00
133	14-03-2024	EFT	WEST WIDE AUTO ELECTRICS	Regassing of Roller - Insurance Claim	2,985.00
134	14-03-2024	EFT	WEST WIDE AUTO ELECTRICS	Replace batteries on Generator at memorial hall	515.00
135	14-03-2024	EFT	WOBM - WHEATBELT OFFICE OF BUSINESS MACHINES - NORTHAM	Monthly Rental of Photocopier - Toodyay Library 2022/2023 January 2024	117.59
136	14-03-2024	EFT	WREN OIL	Annual waste oil collection fees 2023/2024 - Waste Transfer Station Feb 2024	16.50

Electronic Funds Transfer Payments					
137	14-03-2024	EFT	WURTH AUSTRALIA P/TY LTD	Supply store items	231.76
138	14-03-2024	EFT	ZONE 50 ENGINEERING SURVEYS PTY LTD	1077-012 Julimar Road - spotting	4,153.60
139	19-03-2024	EFT	C & F BUILDING APPROVALS	NCC Compliance Assessment - 121 Whitfield Rd, Dumbarton, 24 Tomkins Bend, Nunile & 26	1,430.00
140	19-03-2024	EFT	C & F BUILDING APPROVALS	NCC 227 Timber Creek Crescent, Coondle	385.00
141	19-03-2024	EFT	GLEN FLOOD GROUP PTY LTD	Wayne Butler, Temp for Coordinator of Project Delivery, Depot 4 March - 17 March 20024	8,974.90
142	19-03-2024	EFT	GLEN FLOOD GROUP PTY LTD	Wayne Butler, Temp for Coordinator of Project Delivery, Depot 19 February - 3rd March 2024	8,865.45
143	19-03-2024	EFT	GRANICUS AUSTRALIA PTY LTD	Open Forms Annual License ("Burning Permits" System) 3/4/2024 - 02/04/2025	2,171.57
144	19-03-2024	EFT	MM MECHANICAL PTY LTD	Diagnose and address clutch failure. replace broken bonnet and new latch.	13,291.08
145	19-03-2024	EFT	MM MECHANICAL PTY LTD	Diagnose an Repair charging system, Re gas Air Con, repaid snapped intake brackets, address oil	5,008.44
146	19-03-2024	EFT	MM MECHANICAL PTY LTD	T7861 Repairs/attention to Flywheel and new clutch. Repairs/Maintenance to rear bumper/tail	4,464.90
147	19-03-2024	EFT	MM MECHANICAL PTY LTD	T7853 Diagnose and repaid over heating of cooling system	330.00
148	19-03-2024	EFT	NATURAL AREA CONSULTING MANAGEMENT SERVICES	Chitty Road Upgrade - SLK 4.34-6.34 - Tree Inspection, Revegetation & Monitoring - Year 1	374.00
149	19-03-2024	EFT	S F FITZGERALD PLUMBING & GAS	Supply and install 80mm PVC pressure pipe and fittings to Depot water tanks and connect to Storz	2,731.50
150	19-03-2024	EFT	TEAM GLOBAL EXPRESS PTY LTD	Parcels from Frontline	67.84
151	19-03-2024	EFT	WAYNE GIESEMANN CEILINGS	Replace water damaged/Mould ceiling in Youth Hall store room - Health & Safety Issue	2,772.00
152	28-03-2024	EFT	ARC INFRASTRUCTURE	L3374 Shire of Toodyay Rail Corridor Licence Agreement	220.00
153	28-03-2024	EFT	AUSTRALIAN TAXATION OFFICE - ALBURY	January 2024 BAS	29,543.71
154	28-03-2024	EFT	AUSTRALIAN TAXATION OFFICE - ALBURY	February 2024 BAS	39,106.00
155	28-03-2024	EFT	AUTOPRO NORTHAM	Supply new CV Joint For T0003	265.15
156	28-03-2024	EFT	AUTOPRO NORTHAM	Supply oil filter for T0003	19.00
157	28-03-2024	EFT	AUTOPRO NORTHAM	Supply new tow ball for T0023	39.96
158	28-03-2024	EFT	AVON SKIP BINS	Skip bin empty Sportsground 13 March & 23 February 2023	120.00

Electronic Funds Transfer Payments					
159	28-03-2024	EFT	AVON WASTE - STONDON PTY LTD	Services- Rubbish Waste Removal - 2023 Toodyay International Food Festival	330.00
160	28-03-2024	EFT	AVON WASTE - STONDON PTY LTD	Fortnightly rubbish collection charges 29.01 - 09.02.2024	17,992.37
161	28-03-2024	EFT	AVON WASTE - STONDON PTY LTD	Fortnightly rubbish collection charges Fortnightly Service from 12/02/2024 - 23/02/24	17,295.72
162	28-03-2024	EFT	AVON WASTE - STONDON PTY LTD	Fortnightly rubbish collection charges 26.02 - 08.03.2024	17,343.74
163	28-03-2024	EFT	AVON YARD & MAINTENANCE SERVICES	Install new guttering at Morangup Hall	700.00
164	28-03-2024	EFT	AVON YARD & MAINTENANCE SERVICES	Affixing 3 x information signs to mounts.	200.00
165	28-03-2024	EFT	AVON YARD & MAINTENANCE SERVICES	Fabrication and installation of 4 x interpretive signs - Pelham Reserve.	1,100.00
166	28-03-2024	EFT	BONGERS BEES ENTERPRISES PTY LTD	Restock of honey for sale in VC	345.00
167	28-03-2024	EFT	BRODERICK WASTE SOLUTIONS	Management of waste transfer station for period ending 20 February 2024	5,100.00
168	28-03-2024	EFT	C & F BUILDING APPROVALS	NCC Compliance - 16 Gadsdon Pass, Nunile & 105 Drummondi Dve, Toodyay	770.00
169	28-03-2024	EFT	C & F BUILDING APPROVALS	Bulk PO to cover contract building surveyor services provided by C & F Building Approvals	3,520.00
170	28-03-2024	EFT	C & F BUILDING APPROVALS	Bulk PO to cover contract building surveyor services provided by C & F Building Approvals	1,045.00
171	28-03-2024	EFT	CADDS FASHIONS SPORTFIRST NORTHAM	Mack Terra Pro - Zip Size 11 Colour - Black for Red Allen	224.99
172	28-03-2024	EFT	CADDS FASHIONS SPORTFIRST NORTHAM	Supply new CV Joint For T0003	13.50
173	28-03-2024	EFT	CADDS FASHIONS SPORTFIRST NORTHAM	Steel blue Argyle Zip Boot Size 8.5 Black	206.99
174	28-03-2024	EFT	CARRINGTON'S (WA) PTY LTD	Chitty Rd Upgrade SLK 4.34-6.30 - Seal & Asphalt Works - Traffic Management	5,020.13
175	28-03-2024	EFT	CHARLES SERVICE COMPANY	Cleaning services for March to 20/03/2024	11,215.39
176	28-03-2024	EFT	CHARLES SERVICE COMPANY	Cleaning Meeting Room, little office, computer room 19/02/2024 - 15/03/2024	1,379.40
177	28-03-2024	EFT	CHARLES SERVICE COMPANY	Cleaning of Admin Building 19/02/2024 - 15/03/2024	1,452.00
188	28-03-2024	EFT	CHARLES SERVICE COMPANY	Cleaning Youth Hall from 19/02/2024 - 15/03/2024	532.40
189	28-03-2024	EFT	Charmeine Gail DURl	Councillor Attendance allowance March 2024	1,456.29
190	28-03-2024	EFT	CITY OF ALBANY	Migration fee for data transfer from AMLIB to Civica (Library Management System) to prepare	4,239.40

Electronic Funds Transfer Payments					
191	28-03-2024	EFT	CLOUD COLLECTIONS PTY LTD	Court Filing and Baliff Fees - N Baugh, B & O Moses and P Steele	1,469.60
192	28-03-2024	EFT	CLOUD COLLECTIONS PTY LTD	Court filing & Bailiff Fees - D Lloyd, T Kress and A & D Taylor	2,012.60
193	28-03-2024	EFT	CLUBLINKS MANAGEMENT PTY LTD	Venue Hire for Australia Day 2024	627.95
194	28-03-2024	EFT	CONPLANT PTY LTD	supply & freight new glass window for Ammann Roller.	465.30
195	28-03-2024	EFT	CORE BUSINESS AUSTRALIA PTY LTD	Assistance with the development and implementation of a compliance improvement	2,200.00
196	28-03-2024	EFT	CTI SECURITY	Alarm System monitoring - Community Centre & VC 01 April to 30 June 2024	202.92
197	28-03-2024	EFT	CTI SECURITY	Alarm Monitoring April - June 2024	202.92
198	28-03-2024	EFT	CTI SECURITY	Alarm Monitoring Charges January to March 2024	202.92
199	28-03-2024	EFT	D CLEMENTS SMASH REPAIRS	Repairs to T000 Isuzu MU-X. Insurance Excess	300.00
200	28-03-2024	EFT	Danielle Kim WRENCH	Councillor Attendance allowance March 2024	1,456.29
201	28-03-2024	EFT	DARREN LONG CONSULTING	February preparation Annual Financial Report - audit	4,125.00
202	28-03-2024	EFT	DATACOM SOLUTIONS (AU) PTY LTD	Datascape monthly SaaS fee for February 2024	3,711.11
203	28-03-2024	EFT	DOWNER EDI WORKS LIMITED	Construction of Shared Pathway - Jubilee/Connor Street/ Toodyay Street - WABN Part Grant	110,000.00
204	28-03-2024	EFT	EAG ELECTRICAL AIR-CONDITIONING & GAS	Replace inlet valve to evap air conditioner at 19a Clinton Street	385.00
205	28-03-2024	EFT	EAG ELECTRICAL AIR-CONDITIONING & GAS	Repair lights at old Goal.	889.90
206	28-03-2024	EFT	EAG ELECTRICAL AIR-CONDITIONING & GAS	Service of Air conditioners - Bendigo Bank	176.00
207	28-03-2024	EFT	EAG ELECTRICAL AIR-CONDITIONING & GAS	Supply and install lights to Town oval and Rec centre	6,671.39
208	28-03-2024	EFT	EAG ELECTRICAL AIR-CONDITIONING & GAS	Supply and fit new strip lights to library.	4,236.10
209	28-03-2024	EFT	EAG ELECTRICAL AIR-CONDITIONING & GAS	Check air conditioner at Sports Pavilion Showgrounds. Replace the unit was	264.00
210	28-03-2024	EFT	EASIFLEET	Hugo De Vos payroll salary deductions PPE 27/02/2024	498.10
211	28-03-2024	EFT	EASIFLEET	Hugo De Vos payroll salary deductions PPE 26.3.24	498.10
212	28-03-2024	EFT	FINISHING WA - FORMERLY PRITCHARD BOOK BINDERS	Binding Minutes	1,751.53

Electronic Funds Transfer Payments					
213	28-03-2024	EFT	FRONTLINE FIRE & RESCUE EQUIPMENT	66437 - 70 x 3M P2 Particulate Filter (7 boxes of 10) 66435 - 70 x 3M REtainer Clip (to suit 6000	1,141.91
214	28-03-2024	EFT	FRONTLINE FIRE & RESCUE EQUIPMENT	Signage, jerry can, nozzles, hooklok an adaptors	1,023.00
215	28-03-2024	EFT	FRONTLINE FIRE & RESCUE EQUIPMENT	PTO Check - Morangup 2.4	624.09
216	28-03-2024	EFT	GLEN FLOOD GROUP PTY LTD	Wayne Butler, Temp for Coordinator of Project Delivery, Depot 04.02. - 18.02.2024	3,885.48
217	28-03-2024	EFT	HAYS SPECIALIST RECRUITMENT (AUST) PTY LTD	Payment for Finance Officer-Payroll Temp for W/E 10 March 2024 as per attached	876.81
218	28-03-2024	EFT	HAYS SPECIALIST RECRUITMENT (AUST) PTY LTD	Payment for Finance Officer-Payroll Temp for W/E 25 February 2024 as per attached	2,156.48
219	28-03-2024	EFT	HAYS SPECIALIST RECRUITMENT (AUST) PTY LTD	Payment for Finance Officer-Payroll Temp for W/E 03 March 2024 as per attached	2,011.02
220	28-03-2024	EFT	John Anthony PRATER	Councillor Attendance allowance March 2024	1,456.29
221	28-03-2024	EFT	John BUTLER	Consignment - December 2023	46.20
222	28-03-2024	EFT	KA QUINN & SA ROBINSON	Cabinetry Repairs Moragnup Colocated Emergency Facility	825.00
223	28-03-2024	EFT	KAKADU TRADERS (WG TRUNK CO)	Australian Kangaroo leather hats to sell in the VC	476.30
224	28-03-2024	EFT	KLEEN WEST DISTRIBUTERS	Admin paper towel, hand towel & toilet rolls	174.52
225	28-03-2024	EFT	LANDGATE	Land Title searches - December 2023	152.50
226	28-03-2024	EFT	Lena THOMSON	Reimbursement - Pre-Employment expenses - 14.03.2024	365.70
227	28-03-2024	EFT	MAYDAY RENTAL	Dry hire Dynapac CA3500P 14T Smooth drum roller, including mobilisation fee	6,006.00
228	28-03-2024	EFT	MELISSA GAYE ADAMS	Reserve signage design work.	495.00
229	28-03-2024	EFT	Michael Vincent MCKEOWN	Councillor Attendance allowance March 2024	4,841.42
230	28-03-2024	EFT	Michelle Louise DIVAL	Councillor Attendance allowance March 2024	2,137.18
231	28-03-2024	EFT	MM MECHANICAL PTY LTD	Julimar 2.4 - Clutch Issue investigation -T7124	1,003.29
232	28-03-2024	EFT	MM MECHANICAL PTY LTD	1HCF585 CESM Ute service	2,526.66
233	28-03-2024	EFT	MODDEX GROUP PTY LTD	Install Hand Railing for new steps at Community Centre	1,390.16
234	28-03-2024	EFT	MOORE AUSTRALIA	Final billing in relation the Review of Risk Management, Internal Control & Legislative	6,050.00

Electronic Funds Transfer Payments					
235	28-03-2024	EFT	NATURAL AREA CONSULTING MANAGEMENT SERVICES	Chitty Road Upgrade - SLK 4.34-6.34 - Tree Inspection, Revegetation & Monitoring - Year 1	374.00
236	28-03-2024	EFT	NATURAL AREA CONSULTING MANAGEMENT SERVICES	Chitty Road Upgrade - SLK 4.34-6.34 - Tree Inspection, Revegetation & Monitoring - Year 1	374.00
237	28-03-2024	EFT	NATURAL AREA CONSULTING MANAGEMENT SERVICES	Chitty Road Upgrade - SLK 4.34-6.34 - Tree Inspection, Revegetation & Monitoring - Year 1	374.00
238	28-03-2024	EFT	NATURAL AREA CONSULTING MANAGEMENT SERVICES	Chitty Road Upgrade - SLK 4.34-6.34 - Tree Inspection, Revegetation & Monitoring - Year 1	374.00
239	28-03-2024	EFT	NORTH STAR SECURITY NOMINEES PTY LTD	Alarm System Monitoring - Administration April - June 2024	157.30
240	28-03-2024	EFT	NORTH STAR SECURITY NOMINEES PTY LTD	Alarm System Monitoring - Administration Monitoring January to March 2024	145.20
241	28-03-2024	EFT	NUTRIEN WATER - MIDLAND	Supply 40 x Hunter I20 S/S gear drive sprinklers	1,658.80
242	28-03-2024	EFT	NUTRIEN WATER - MIDLAND	Supply male camlocks for Truck 10.	53.04
243	28-03-2024	EFT	NUTRIEN WATER - MIDLAND	RainBird and Hunter sprinklers, nozzles and controllers	4,015.01
244	28-03-2024	EFT	OFFICEWORKS	Stationery - CRC, Admin and Freight	129.37
245	28-03-2024	EFT	PENTANET LIMITED	NBN business unlimited data for 15 Fiennes St, Library & VC March 2024	784.89
246	28-03-2024	EFT	PROFESSIONAL PC SUPPORT PTY LTD (XL2)	Managed phone agreement April 2024	1,244.03
247	28-03-2024	EFT	PROFESSIONAL PC SUPPORT PTY LTD (XL2)	Managed ITC agreement April 2024	10,305.01
248	28-03-2024	EFT	PUBLIC TRANSPORT AUTHORITY OF WA	TransWA ticket sales 01 November - 4 November 2023	47.02
249	28-03-2024	EFT	PUBLIC TRANSPORT AUTHORITY OF WA	TransWA ticket Sales 05 November - 11 November 2023	49.30
250	28-03-2024	EFT	PUBLIC TRANSPORT AUTHORITY OF WA	TransWA ticket sales 13 November - 19th November 2023	115.70
251	28-03-2024	EFT	PUBLIC TRANSPORT AUTHORITY OF WA	TransWA ticket sales 22 November - 30 November 2023	140.55
252	28-03-2024	EFT	PUBLIC TRANSPORT AUTHORITY OF WA	TransWA ticket sales 01 December - 09 December 2023	14.80
253	28-03-2024	EFT	PUBLIC TRANSPORT AUTHORITY OF WA	TransWA ticket sales 11 December - 15 December 2023	189.89
254	28-03-2024	EFT	Reuben Gregory Barbrec CAMPBELL	Reimbursement - Travel - R Campbell 13-14 March 2024	627.00
255	28-03-2024	EFT	ROAD AND TRAFFIC SERVICES	Julimar Road - Edgebreaks - SLK 10.17 - 12.17 - Line Marking Works	12,765.17
256	28-03-2024	EFT	Rosemary June MADACSI	Councillor Attendance allowance March 2024	1,456.29

Electronic Funds Transfer Payments						
257	28-03-2024	EFT	S F FITZGERALD PLUMBING & GAS	Cleaning of sewer drains at Connors Cottage		418.00
258	28-03-2024	EFT	SHIRE OF NORTHAM	AROC Workforce Housing Solutions Project		10,000.00
259	28-03-2024	EFT	SONIC HEALTHPLUS PTY LTD	Audiometry Testing for Kyle Woollams		77.00
260	28-03-2024	EFT	SONIC HEALTHPLUS PTY LTD	Audiometry Testing for Mark Roberts		77.00
261	28-03-2024	EFT	SOUTHERN CROSS AUSTEREO PTY LTD	Triple M Around the Towns Interviews 2024		99.00
262	28-03-2024	EFT	SPACETOCO PTY LTD	Host ParterPro Bundle (Reporting and Service) - Online Booking facilities for March 2024		165.00
263	28-03-2024	EFT	Steven John MCCORMICK	Councillor Attendance allowance March 2024		1,456.29
264	28-03-2024	EFT	STRUCTERRE CONSULTING ENGINEERS	Soil Test 56 Bejoording Road - Proposed Bejoording Fire Station Planning		1,910.70
265	28-03-2024	EFT	SYNERGY	Electricity Account 802970900		7,686.80
266	28-03-2024	EFT	SYNERGY	Streetlights- Electricity Account 174585790 - January 2024 - inclusive of Credit Inv		6,826.62
267	28-03-2024	EFT	SYNERGY	Streetlights, Electricity Account 174585790 - February 2024		4,346.23
268	28-03-2024	EFT	TEAM GLOBAL EXPRESS PTY LTD	Henderson hoses, Stewart & Hanson and Frontline deliveries		193.31
269	28-03-2024	EFT	TELSTRA CORPORATION LTD	Telstra mobiles and data account 2608284176		1,337.36
270	28-03-2024	EFT	TELSTRA CORPORATION LTD	Telstra account telephone & internet 0293288400 December 2023		2,490.25
271	28-03-2024	EFT	THE DOG LINE PTY LTD	INV: s-23934 Dangerous Dog equipment		187.00
272	28-03-2024	EFT	THE PRINT SHOP WHEATBELT	Artist Cards for Gallery at CRC - Stronger Community Grant - 2023		184.80
273	28-03-2024	EFT	TOODYAY HARDWARE & FARM	Monthly Hardware Purchases - Hose clear reinforced x 6		67.50
274	28-03-2024	EFT	TOODYAY HARDWARE & FARM	Monthly Hardware Purchases - March 2024 Poly sockets x 10		49.50
275	28-03-2024	EFT	TOODYAY HARDWARE & FARM	Monthly Hardware Purchases - March 2024 Silicone		13.95
276	28-03-2024	EFT	TOODYAY HARDWARE & FARM	Monthly Hardware Purchases - March 2024 - adhesive		34.50
277	28-03-2024	EFT	TOODYAY HARDWARE & FARM	Monthly Hardware Purchases - January 2024 - Socket poly		3.75
278	28-03-2024	EFT	TOODYAY HARDWARE & FARM	Monthly Hardware Purchases - January 2024 - Gripple		25.00

Electronic Funds Transfer Payments					
279	28-03-2024	EFT	TOODYAY HARDWARE & FARM	Monthly Hardware Purchases -January 2024 - Solenoid Valve	39.95
280	28-03-2024	EFT	TOODYAY HARDWARE & FARM	Monthly Hardware Purchases - January 2024 - Starposts	47.85
281	28-03-2024	EFT	TOODYAY HARDWARE & FARM	Monthly Hardware Purchases - January 2024 - Pipe riser & PVC	19.05
282	28-03-2024	EFT	TOODYAY HARDWARE & FARM	Monthly Hardware Purchases - January 2024 PVC pipe	38.85
283	28-03-2024	EFT	TOODYAY HARDWARE & FARM	Monthly Hardware Purchases - January 2024	30.00
284	28-03-2024	EFT	TOODYAY HARDWARE & FARM	Monthly Hardware Purchases - January 2024	45.95
285	28-03-2024	EFT	TOODYAY HARDWARE & FARM	Monthly Hardware Purchases - January 2024	63.35
286	28-03-2024	EFT	TOODYAY HARDWARE & FARM	Monthly Hardware Purchases - January 2024 Cloth Tape - Australia Day	35.25
287	28-03-2024	EFT	TOODYAY HARDWARE & FARM	Monthly Hardware Purchases - January 2024- Nipple poly 3/4	11.25
288	28-03-2024	EFT	TOODYAY HARDWARE & FARM	Monthly Hardware Purchases - January 2024 Socket PVC	8.50
289	28-03-2024	EFT	TOODYAY HARDWARE & FARM	Monthly Hardware Purchases - January 2024	49.90
290	28-03-2024	EFT	TOODYAY TRADERS	Aquadhere interior	17.50
291	28-03-2024	EFT	TOODYAY TRADERS	Monthly Hardware Purchases - February 2024	27.25
292	28-03-2024	EFT	TOODYAY TRADERS	Poly nipple	4.50
293	28-03-2024	EFT	TOODYAY TRADERS	Monthly Hardware Purchases - February 2024 - \$60 maximum	10.50
294	28-03-2024	EFT	TOODYAY TRADERS	Monthly Hardware Purchases - February 2024 - Jug	35.75
295	28-03-2024	EFT	TOODYAY TYRE & EXHAUST	1HPT-112 2 x new Tyres for RMO Vehicle	640.00
296	28-03-2024	EFT	VERNICE PTY LTD	Julimar Rd - SLK 19.81 – 22.52 - Gravel Supply as per Tender Contract	217,784.27
297	28-03-2024	EFT	WALGA	Individual e-learning enrolments - Cr Prater	869.00
298	28-03-2024	EFT	WEST WIDE AUTO ELECTRICS	Central 12.2 - Transmission ECU replacement and clearance lights rewiring	5,786.60
299	28-03-2024	EFT	WEST WIDE AUTO ELECTRICS	Julimar 2.4 - Wiring Repairs Back Deck	577.30
300	28-03-2024	EFT	WEST WIDE AUTO ELECTRICS	Coondle 1.4 - air compressor and lighting fault	558.00

Electronic Funds Transfer Payments					
301	28-03-2024	EFT	WEST WIDE AUTO ELECTRICS	Toodyay Central 4.4 - Lighting and siren fault	448.50
302	28-03-2024	EFT	WEST WIDE AUTO ELECTRICS	Julimar 1.4 - DPF repair	562.50
303	28-03-2024	EFT	WINC AUSTRALIA P/L	2mtr High Speed Hdmi Cable	10.53
304	28-03-2024	EFT	WINC AUSTRALIA P/L	Paper Cups 7oz x 1000	261.05
305	28-03-2024	EFT	WINC AUSTRALIA P/L	Stationery for P&D, VC, CRC and Admin	603.57
306	28-03-2024	EFT	WINC AUSTRALIA P/L	Admin Stationery - Brother desktop Scanner	588.85
307	28-03-2024	EFT	WINC AUSTRALIA P/L	Stationery - CRC, Depot, Admin and P&D - March	365.99
308	28-03-2024	EFT	WRIGHT EXPRESS AUST PTY LTD	SES Fuel Card Fees	23.07
EFT Total					1,467,440.87
Payments Payroll					
Ref#	Date	Description			Inclusive Amount
309	05.03.2024	Payroll PPE 05.03.2024			14225.79
310	07.03.2024	Payroll PPE 07.03.2024			20274.23
311	13.03.2024	Payroll PPE 13.03.2024			93083.15
312	28.03.2024	Payroll PPE 28.03.2024			97065.25
313	13.03.2024	Superannuation PPE 12.03.2024			18,612.75
314	27.03.2024	Superannuation PPE 26.03.2024			19,385.30
Payroll Total					262,646.47

Purchasing Cards - FM Regulations 13A				
Ref#	Date	Creditor Name	Invoice Description	Inclusive Amount
315		CC - CEO - February	Zoom subscription - AROC	223.90
316			International fee	6.72
317			Card fee	4.00
318			Adobe subscription	802.81
Other Total				1,037.43
Purchasing Cards - FM Regulation 13A				
Ref#	Date	Creditor Name	Invoice Description	Inclusive Amount
319		CC - MDR -December	BP Ballajura	70.00
320			ChatGPT	32.89
321			International Transaction Fee	.99
322			Card Fee	4.00
Other Total				107.88
323		CC - MDR - January	Alfordson Ergonomic Chair	259.64
324			ChatGP	33.72
325			Boost prepaid - Credit	8
326			International Transaction Fee	1.01
327			Card Fee	4.00
328			Officeworks	29.34
Other Total				320.21
329		CC - MAS - January	Officeworks	318.61
330			Burst SMS	1528.50
331			Farewell gift - Jasmin Bear	155.95
332			Card Fee	4.00
333			Valve Warehouse	450.78

Purchasing Cards - FM Regulation 13A				
Ref#	Date	Creditor Name	Invoice Description	Inclusive Amount
			Other Total	2,457.84
334		CC - CESM -January	Card Fee	4.00
			Other Total	4.00
335		CC - MCCS - January	Dunnings incident 657041	41.9
336			Ampol incident 657041	15.95
337			Ampol incident 657041	98.93
338			BP incident 657041	59.58
339			BP incident 657041	14.99
340			BP incident 657041	109.16
341			Dunnings incident 657041	83.51
342			Widgiemooltha Roadhouse incident 657041	130.98
343			Card fee	4.00
			Other Total	559.00
344		CC - MCCS - January	Facebook	33.46
345			International transaction fee	1.00
346			Adobe	18.69
347			Card fee	4.00
			Other Total	57.15

Purchasing Cards- FM Regulation 13A				
REF#	Date	Creditor Name	Invoice Description	Inclusive Amount
348	11.03.2024	Purchasing Card - Library	Big W Online Vista Aus	114.00
349	11.03.2024		Booktopia Pty Ltd	88.74
			Other Total	202.74
			Purchasing Card Total	4,746.25
			Total Payments	1,865,714.59

From: Daniel Dadd

Sent: Friday, 23 February 2024 7:17 AM

Subject: ICR94596 - [External]-Toodyay Tennis Club Annual Fee - Formal Request for waiver

Good Morning President and Councillor,

The Toodyay Tennis Club would like to request the balance of the annual booking fee (\$2,530) payable to Clublinks be formally waived for this season (Oct 23 - Sept 24). For the reasons outlined in our prior correspondence.

We look forward to your consideration of our request and response.

Regards

The Toodyay Tennis Club Committee.

Treasurer - Daniel Dadd



PO Box 357 Toodyay 6566

<https://play.tennis.com.au/toodyaytennisclub>

From: Redacted Information <[@dlgsc.wa.gov.au](mailto:dlgsc.wa.gov.au)>
Sent: Tuesday, March 26, 2024 2:43 PM
To: Tabitha Bateman <Redacted Information@toodyay.wa.gov.au>; Councillor McKeown <cr.mckeown@toodyay.wa.gov.au>
Subject: [External]-Shire of Toodyay Charter

Afternoon Tabitha and Shire President Cr. McKeown,

I hope this email finds you well. I apologise in the delay in getting this to you.

Attached is an annotated version of the Shire's charter and a document with comments against each of the Shire's reasonings for amending the clauses.

In accordance with the below it would be beneficial for the LG to have the final charter reviewed by a legal professional.

The Shire's charter has removed a lot of items citing that the legislation deals with it or that it is a responsibility of the CEO. The Shire also appears to say that the OAG guidelines is a guide and not intended for all but in the next sentence say they should stick to the guide. The Shire appears to have misinterpreted the statements in the OAG's guide as though the ARC is performing a function where in fact they are providing a third party overview of a function administered by the CEO.

While the majority of the functions that the ARC has were removed, we have assessed they should remain however, a valid point was raised by the team in their assessment in particular; that the local government ARC may not be able to attract people with the appropriate experience to effectively conduct these functions due to its size/location and that the ARC councillors could potentially use the charter against administration. This may not have been the intent but certainly has in our assessment given the Department of Local Government, Sport and Cultural Industries this impression.

For the ARC to be made an effective tool for the Shire, consideration should be given to either:

- Insert the deleted functions, but amend them to ensure that the ARC are undertaking a review function, or
- Insert the deleted functions and enhance clause 1.2 to ensure that the ARC only operate in a review capacity.

The team have had a look at the City of Swan's and City of Cockburn's audit charters and have made the following observations:

- In parts where a legislative reference is provided, it may be beneficial to include the information from the legislative reference so members do not need to refer to the Act and Charter in understanding their role.
- Both COS and COC outline the minimum number of members and the number of independent members, it would be beneficial for the Shire to add this in.

- The Shire should divide up its auditing section to differentiate between the Committee's internal and external audit functions similar to the COS.
- To minimise disputes between the administration and the ARC, the charter should clearly establish:
 - Clear lines of reporting between the ARC and administration.
 - what training and induction materials will be provided to ARC members.
 - What timeframes the ARC will receive agendas/minutes and the respective accompanying reports before/after each meeting similar to COC.

I hope the above assists the Shire in revising the Charter.

Kind Regards

Redacted Information

Director Local Government Financial Policy and Statutory Approvals

Department of Local Government, Sport and Cultural Industries
140 William Street, Perth WA 6000
GPO Box R1250, Perth WA 6844

Redacted Information

Web: www.dlgsc.wa.gov.au

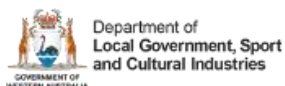

MEMORANDUM

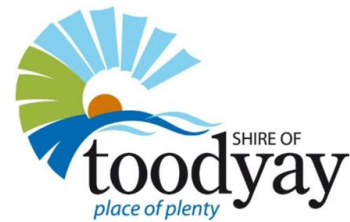

MEMO TO: Bush Fire Advisory Committee

FROM: **Charles Sullivan**
Executive Manager
Infrastructure, Assets and Services

DATE: 3 April 2024

FILE NO: FIR3

SUBJECT: Schedule of Preventive Maintenance Fire Stations

Administration Centre

15 Fiennes Street
PO Box 96
TOODYAY WA 6566

T (08) 9574 9300

F (08) 9574 2158

E records@toodyay.wa.gov.au

W www.toodyay.wa.gov.au

The current program of maintenance tasks for the fire stations is shown below.

- Gutter Cleaning Annually [B],[C],[J],[M]
- Airconditioning Service Annually [B],[C],[J],[M]
- Water Filters Bi-Annually [C],[J],[M]
- Rodent Control (quarterly) [B],[C],[J],[M]
- Termite Treatment Annually [B],[C],[J],[M]
- Insect Inside/Outside Annually (or as required) [B],[C],[J],[M]
- Fire Extinguisher Testing Bi-annually [B],[C],[J],[M],[T*]
- Roof Safety System Check/Certification Bi-annually [C],[J],[M]
- Roller doors Annually [B],[C],[J],[M]

Fire Extinguisher Details:

Please note this includes:

- BFS Appliances at Toodyay Colocation Centre (Toodyay Central 1.4, Toodyay Central 4.4, Toodyay 12.2) - not red trucks or building)
- FSV1, FSV2 and spare fire service extinguishers held at the Shire Depot.

Airconditioning Details:

Coondle & Julimar – 4 x Split System (4 x external component roof mounted, internal components 1xComms Room, 1xOffice, 2xTraining Room)

Morangup – 6 x Split System (2 x external component ground mounted, internal components 1xComms Room, 1xBFS Office, 1xSES Office, 3xTraining Room)

Bejoording – 1 x Split System (1 x external component ground mounted, internal component 1xOffice)

Water Filter Details:

Filters every 6 months

Lamps every 12 months

<https://www.puretec.com.au/site/User%20Guides/Puretec%20Hybrid%20Series%20User%20Guide.pdf>

Contractor: Leon info@floworplumbing.com.au

Roof Safety System Certification:

Bi-annually (or at least annually)

Contractor:

Richard Wilkinson richard@safemaster.net.au

Tyron Menikides inspections@safemaster.net.au

Locations & Plans:

To assist contractors, facility location maps/info and building layout diagrams (inc. Access Codes) are shown here: [W:\CESM\brigades\ContractorDiagramsInfo](#)

Charles Sullivan

Executive Manager Infrastructure, Assets and Services



Existing Structure
 Toodyay Race Club Precinct, Toodyay
 Structural Report
 24-0564

Existing Structure Toodyay Race Club Precinct, Toodyay STRUCTURAL REPORT

Prepared for: Shire of Toodyay

Job Number: 24-0564

2 April 2024

REV	DATE	PREPARED	APPROVED	DESCRIPTION
0	2 April 2024			Issued to Client



Existing Structure
 Toodyay Race Club Precinct, Toodyay
 Structural Report
 24-0564

Contents

Introduction.....3

Background4

Observations5

 Main Structural Elements6

 Base Connection.....6

 Steel Portal Frame8

 Purlins.....10

 Roof sheeting.....13

 Ancillary items15

 Wall cladding.....15

 Enclosed Space17

Discussion & Recommendations.....18

 Column Base Connection18

 Steel Portal Frame18

 Purlins.....19

 Roof Sheeting20

 Wall Cladding21

 Enclosed Room21

Conclusions21

Appendix22



Existing Structure
Toodyay Race Club Precinct, Toodyay
Structural Report
24-0564

Introduction

This office was engaged by the Shire of Toodyay to carry out a structural inspection and assessment of the main undercover shelter structure at the Toodyay Racecourse. An inspection was carried out by this office on Tuesday, 26 March 2024 and comprised a visual inspection of the various components of the structure. This report serves to provide comment on the condition of the structure and provide recommendations regarding remedial works where required.



MAIN STRUCTURE



Existing Structure
 Toodyay Race Club Precinct, Toodyay
 Structural Report
 24-0564

Background

The undercover shelter is a single level structure approximately 42m x 26m. The construction consists of bitumen & gravel hardstand area, steel portal frames, steel purlins and aluminium roof sheeting.

The age of the structure is unknown, but is it expected to be at least 50 years old.

Based on the geological charts for the area, it is anticipated that the site would be classified as Class S to Class M in accordance with AS2870 indicating Slightly to Moderately reactive soils. The site has been assessed in accordance with AS1170.2 Wind Actions and has an expected ultimate design wind speeds of 39.3m/s. The Corrosivity Classification of C2 (Low) in accordance with AS4312 would be applicable for this site.



SATELLITE VIEW OF EXPOSURE OF STRUCTURE



Existing Structure
 Toodyay Race Club Precinct, Toodyay
 Structural Report
 24-0564

Observations

The below items are ranked by their overall condition to ease of reference, utilising the grading and descriptions below.

CONDITION GRADE	DESCRIPTION
1	Element is in new or as new condition. No signs of damage, deterioration, or other issues
2	Element is starting to show signs of deterioration, aging or wear and tear
3	Element is deteriorated, aged or showing obvious signs of wear and tear
4	Element is close to end of useful life and showing significant signs of deterioration
5	Element has failed

TABLE 1- ELEMENT CONDITION RANK

Below is a summary of the various elements for ease of reference:

Element	Condition Grade
Base Connection	4
Steel Portal Frame	3
Purlins	4-5
Roof sheeting	5
Wall Cladding	5
Enclosed Space	5



Existing Structure
 Toodyay Race Club Precinct, Toodyay
 Structural Report
 24-0564

Main Structural Elements

Base Connection

Condition Grade 4

The base of the columns are for the most part concealed by gravel and bitumen, with most being founded just below surface level, but with some +200mm below the main surface.

There are signs of reinforcement/strengthening to most of the column bases, which involved welding a plate between the base plate and column.

In multiple locations the base plates were exposed and the area cleaned to view the condition of this element. In most instances the column bases which were protected from the weather appeared to be performing well, with only minor corrosion visible. The condition of the column based on the extremities of the building (exposed to weather and direct wetting) were affected by corrosion but without significant material loss.



PICTURE 1 – CONCEALED BASE PLATE



PICTURE 2 – CONDITION OF NUT AND THREAD – CORROSION MATERIAL IN PLACE



Existing Structure
Toodyay Race Club Precinct, Toodyay
Structural Report
24-0564



PICTURE 3 – CONDITION OF NUT WITH CORRODED MATERIAL REMOVED



PICTURE 4 – NUT NO LONGER IN PLACE. POSSIBLE SITE WELDING REPAIR HAS BEEN CARRIED OUT



PICTURE 5 – BASE PLATE CONDITION INTERNAL & PROTECTED FROM WEATHER



PICTURE 6 – BASE PLATE BELOW GROUND & COLUMN REINFORCEMENT



Existing Structure
 Toodyay Race Club Precinct, Toodyay
 Structural Report
 24-0564

Steel Portal Frame

Condition Grade 3

The main structural steel frame consists of a Universal Beam (UB) section for both the columns and beam, with being the specific member size 310UB40.4 for both items.

The main roof beam's span is approximately 18,000mm with a 4,200mm cantilever at each end. The beam is pitched with a bolted splice at the ridge (midpoint). The beam's bottom flange is rotationally restrained at regular locations. Bays of cross bracing are also present between some roof beams. There is no bracing between the columns in either direction, indicating the structure relying on 'portal frame action' for its stability. These portal frames are spaced at 6,100mm centres in a grid line pattern.

The steelwork is exhibiting varying levels of corrosion to the surface, with some locations (commonly towards the eave overhang) where the surface protection has been completely lost, with just the bare metal exposed.



PICTURE 7 – TYPICAL STEELWORK LAYOUT



PICTURE 8 – TYPICAL STEELWORK LAYOUT



Existing Structure
Toodyay Race Club Precinct, Toodyay
Structural Report
24-0564



PICTURE 9 - TYPICAL RIDGE/BRACING/STRUT CONNECTION



PICTURE 10 - CORROSION



PICTURE 11 - EXAMPLE OF EXTENT OF CORROSION TO STEEL BEAM (SEVERE)



PICTURE 12 - EXAMPLE OF EXTENT OF CORROSION TO STEEL BEAM (TYPICAL)



Existing Structure
 Toodyay Race Club Precinct, Toodyay
 Structural Report
 24-0564

Purlins

Condition Grade	4-5
------------------------	------------

The purlins consisted of a cold -formed lipped ‘C’ profile which is 150mm high (C150). The thickness of the profile is unknown, but is typically either 1.2mm or 1.5mm thick. The purlins are connected to the main steel beams with cleat and bolts. At regular intervals, there are purlins which are ‘doubled-up’ which coincide with a larger cleat and additional bolts at the steel beam which acts as a critical rotational restraint to the steel beams.

Typically the purlins are exhibiting varying levels of corrosion to the surface, with some locations where the surface protection has been completely lost, with just the bare metal exposed.

The purlins to the location where the roof sheet has been lost can be classified as having failed, as the corrosion is that severe that the edge material can be crumbled by hand (see image below).

At one location, the roof sheeting was manually lifted to view the condition of the top of the purlin, which typically can trap moisture and experience accelerated corrosion. At this location moderate corrosion was present, but no-more advanced than could be located elsewhere on the purlins.



PICTURE 13 – SEVERE CORROSION TO PURLIN



PICTURE 14 – CORROSION TO TOP OF PURLIN (ROOF SHEET MANUALLY REMOVED)



Existing Structure
Toodyay Race Club Precinct, Toodyay
Structural Report
24-0564



PICTURE 15 - TYPICAL PURLIN CLEATED CONNECTION



PICTURE 16- TYPICAL 'DOUBLED-UP' PURLIN CONNECTION



PICTURE 17 - TYPICAL PURLIN CORROSION EXAMPLE



PICTURE 18 - TYPICAL PURLIN CORROSION EXAMPLE



Existing Structure
Toodyay Race Club Precinct, Toodyay
Structural Report
24-0564



PICTURE 19 – TYPICAL PURLIN CORROSION EXAMPLE



PICTURE 20 – TYPICAL PURLIN CORROSION EXAMPLE



Existing Structure
 Toodyay Race Club Precinct, Toodyay
 Structural Report
 24-0564

Roof sheeting

Condition Grade 5

The roof sheeting is an aluminium sheet with a profile similar to Trimdeck™. To the underside, the sheeting appears to be performing well, but when viewed from the top, there are large amounts of damage, bends, creases, and sections with additional sheets laid on top to correct past issues experienced with the roof cover.

There are many locations where the integrity of the aluminium has been lost around the screws where galvanic corrosion has occurred, as can be seen in the image below.

Typically, when using aluminium roof sheeting this requires isolation to carbon steels, eg steel purlins, cleats, bolts etc. This can be done in many ways, but there were no indicators on site of any of these isolators being present.



PICTURE 21 – ALUMINIUM ROOF SHET PROFILE



PICTURE 22 – GALVANIC CORROSION AT SCREW LOCATION.



Existing Structure
Toodyay Race Club Precinct, Toodyay
Structural Report
24-0564

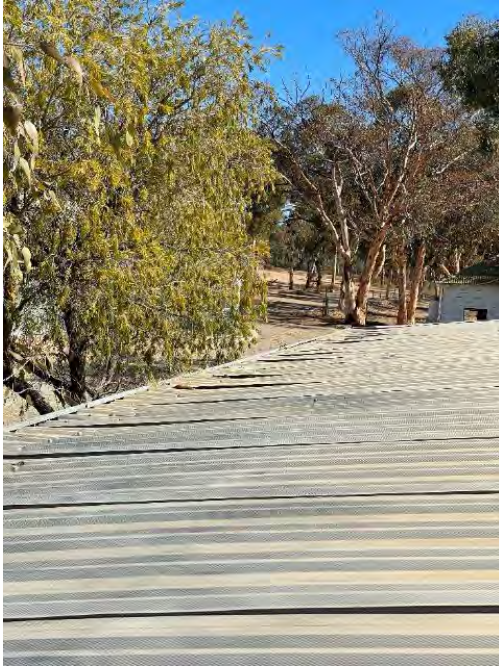

PICTURE 23

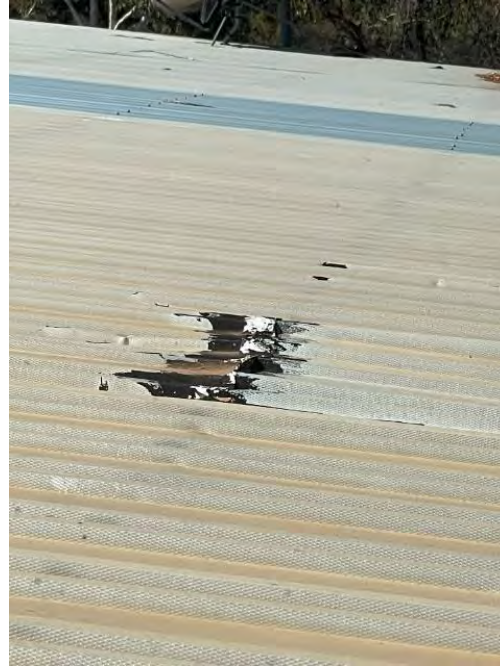

PICTURE 24



PICTURE 25



PICTURE 26



Existing Structure
 Toodyay Race Club Precinct, Toodyay
 Structural Report
 24-0564

Ancillary items

Wall cladding

Condition Grade 5

Wall cladding has been installed to some of the faces of the structure. Although the condition of the members appears to be adequate, the connections and restraints of these are inadequate.

The base of the columns (which support the girts) are not fixed at the base but have a loose bracket placed over brickwork below. This allows the wall to be pushed by hand back and forth. The connection at the top is to the last purlin, which when loaded in this manner is bending through its weak axis and is grossly undersized for the design loads which would apply to this member.



PICTURE 27 – COLUMN BASE CONNECTION



PICTURE 28 – COLUMN TOP CONNECTION



Existing Structure
Toodyay Race Club Precinct, Toodyay
Structural Report
24-0564



PICTURE 29 – TYPICAL ENCLOSED SIDE OF STRUCTURE



PICTURE 30 – COLUMN SUPPORTING GIRTS



Existing Structure
 Toodyay Race Club Precinct, Toodyay
 Structural Report
 24-0564

Enclosed Space

Condition Grade 5

The enclosed room could not be accessed and was locked at time of inspection, but observations were made from heights where possible. From what could be observed, the ceiling appears to have severely sagged and deformed and is in poor condition.



PICTURE 31 – COLLAPSED CEILING



PICTURE 32 – COLLAPSED CEILING



Existing Structure
 Toodyay Race Club Precinct, Toodyay
 Structural Report
 24-0564

Discussion & Recommendations

All the defects identified are the result of corrosion due to exposure to the atmosphere and dissimilar metals (aluminium and carbon steel).. In no area was there any sign of excessive deflection, over-stress, deformation, impact-damage, or other indicators of poor performance. The severity of the corrosion observed varied from minor loss of paint coating to mild surface rust, minor pitting of the surface to flaking and potential loss of material.

The primary concern with excessive corrosion is the loss of thickness of the original steel member which can alter the ultimate strength capacity of the member.

Below are recommendations based on each element type, as well as a timeline to implement that recommendation.

Column Base Connection

Timeframe	6 months
-----------	----------

The connection at the base of the column is critical for the structure's integrity for both its stability and to hold the structure down in high wind events.

Recommendation: Expose all base plates and base connections back to bare metal, with all bitumen coating and previous paint protection removed to allow for a thorough assessment of this element's condition.

Following this, further advice will be able to be provided as to the remediation involved. If in good condition the surface protection to the steelwork can be reinstated with a suitable primer and topcoat system.

Steel Portal Frame

Timeframe	24 Months
-----------	-----------

The condition of the steelwork's surface protection is quite poor, but due to the geographic location, as well as the structure being exposed and easily viewed, this is not a large concern.

Recommendation: the asset owner should determine the desired lifespan of the structure to allow further advice to be provided as to the steelworks surface protection. There is no immediate concern with the steelwork's condition, but the loss of surface protection will allow corrosion rates to accelerate on these members. At some point when the corrosion reaches a severe stage this will pose a structural concern. The timeframe on this is unknown and should be monitored. Typical treatment would include removal of all the corrosion deposits by mechanical abrasion or blasting and the application of a painted protection system suitable for C2.



Existing Structure
 Toodyay Race Club Precinct, Toodyay
 Structural Report
 24-0564

Purlins

Timeframe	6 Months
------------------	-----------------

Recommendation: Although most purlins are in no immediate danger of failure, as the roof sheeting is to be replaced and there is moderately to highly developed corrosion, the purlins should also be replaced. Treatment of purlins by means of cleaning off the corrosion and painting is not considered practical due to their relatively thin guage.

The replacement should be a similar profile as previously installed, but due to the increased sheeting mass, some modifications should be made.

Size: Z15012

Spacing: to suit existing cleats (approx. 1200mm)

Laps: 900mm over each support (beam). Laps to be bolted as per manufactures recommendations (below)

Bridging: Midspan

Fixing: M12 purlin bolts to suit existing cleats.

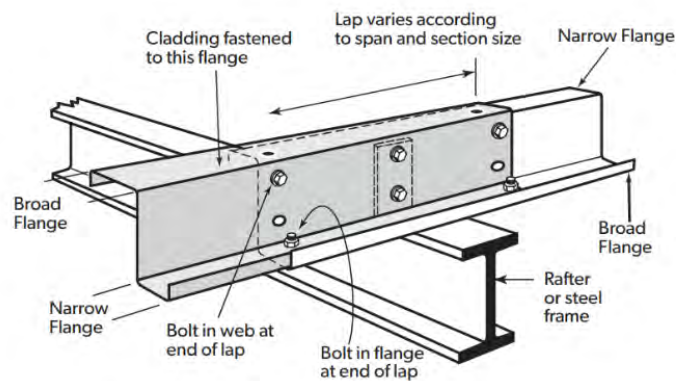

TYPICAL PURLIN LAPPING DETAIL



Existing Structure
 Toodyay Race Club Precinct, Toodyay
 Structural Report
 24-0564

Roof Sheeting

Timeframe **6 Months**

Typically, when using aluminium roof sheeting this requires isolation to carbon steels, eg steel purlins, cleats, bolts etc. This can be done in a few ways, but typically a PVC or polythene tape between the 2 surfaces in contact. Connections between these 2 different metals (eg screws) is done with a stainless steel 304/316 alternative.

This office has carried out an analysis to determine the affect that the additional weight of the sheeting material aluminium vs steel may make on the structure. Aluminium is approximately 1/3rd the weight of steel and although the dead load of this material significantly increases in volumes over the entire structure (1200m²). Ultimately the additional load per square meter is 2.8kg, which to place that into perspective is 1/5th of the minimum imposed load which would be placed this roofing structure to account for maintenance personnel etc. Imposed loads and dead loads and their effect on the designs are different, but the below is a quantifiable example to explain this office's recommendations.

Recommendation: Replace the roof sheeting with a suitable profile. Utilising a similar Aluminium sheet does impose cost implications for all facets of the works including supply, install and the additional items for isolation/stainless steel screws.

Therefore, this office's recommendation to replace the sheeting with a steel (Colorbond) alternative. One example is a 0.42BTM Superdek sheet from Stratco, which its end span will exceed the existing 1200mm purlins spacing.

TABLE 5.0 - SPANS (mm) - Determined by wind speeds for non cyclonic areas

BMT	Application	Span Type	WIND CLASSIFICATION			
			N1 (W28)	N2 (W33)	N3 (W41)	N4 (W50)
0.35mm	Walling	Single	1700	1700	1600	1450
		End	2200	2200	2000	1550
		Internal	2500	2500	2250	1700
0.42mm	Roofing	Single	1150	1150	1150	1150
		End	1350	1350	1350	1350
	Internal	1900	1900	1900	1500	
	Walling	Single	2350	2100	1850	1700
		End	2850	2550	2250	1700
Internal		3000	3000	2600	1950	
0.48mm	Roofing	Single	1700	1700	1700	1500
		End	1900	1900	1900	1500
		Internal	2600	2600	2350	1800
	Walling	Single	2800	2400	2000	1950
		End	3200	2950	2550	2050
		Internal	3300	3300	2900	2250



Existing Structure
 Toodyay Race Club Precinct, Toodyay
 Structural Report
 24-0564

Wall Cladding

Timeframe **Immediately**

These modifications are not structurally sound and should be removed.

If reinstatement of the walls is desired, these should be designed and detailed by someone suitably qualified.

Enclosed Room

Timeframe **Immediately**

The enclosed room should not be accessed, and no personnel should access or store anything on the space over this area.

If use of this area is required, this should be closely reviewed by a someone suitably qualified.

Conclusions

This office was engaged by the Shire of Toodyay to carry out a structural inspection and assessment of the main undercover shelter structure at the Toodyay Racecourse. The inspection identified several items requiring attention with this office supplying remediation where possible as well as timelines for remediation/action to occur.



Existing Structure
Toodyay Race Club Precinct, Toodyay
Structural Report
24-0564

Appendix



PICTURE 33



PICTURE 34



PICTURE 35



PICTURE 36



Existing Structure
Toodyay Race Club Precinct, Toodyay
Structural Report
24-0564



PICTURE 37



PICTURE 38



PICTURE 39



PICTURE 40



Existing Structure
Toodyay Race Club Precinct, Toodyay
Structural Report
24-0564



PICTURE 41

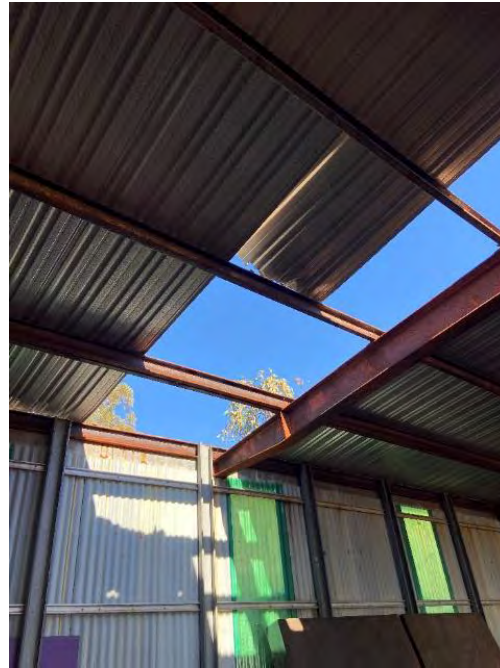

PICTURE 42



PICTURE 43



PICTURE 44



Existing Structure
Toodyay Race Club Precinct, Toodyay
Structural Report
24-0564



PICTURE 45



PICTURE 46



PICTURE 47



PICTURE 48



Existing Structure
Toodyay Race Club Precinct, Toodyay
Structural Report
24-0564



PICTURE 49



PICTURE 50



PICTURE 51

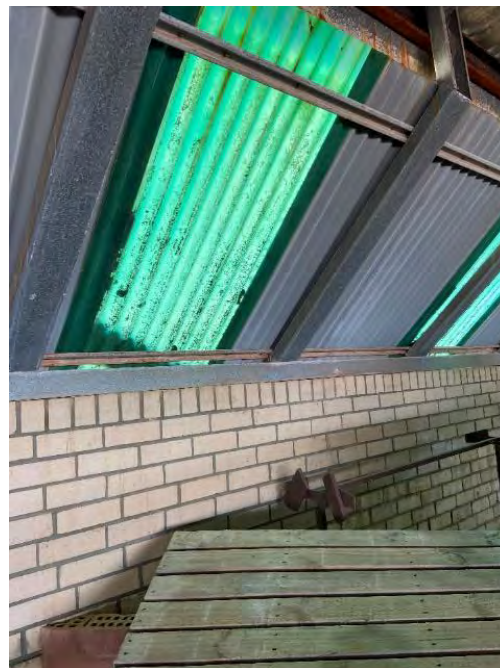

PICTURE 52



Existing Structure
Toodyay Race Club Precinct, Toodyay
Structural Report
24-0564



PICTURE 53



PICTURE 54



PICTURE 55



PICTURE 56



Existing Structure
Toodyay Race Club Precinct, Toodyay
Structural Report
24-0564



PICTURE 57



PICTURE 58



PICTURE 59

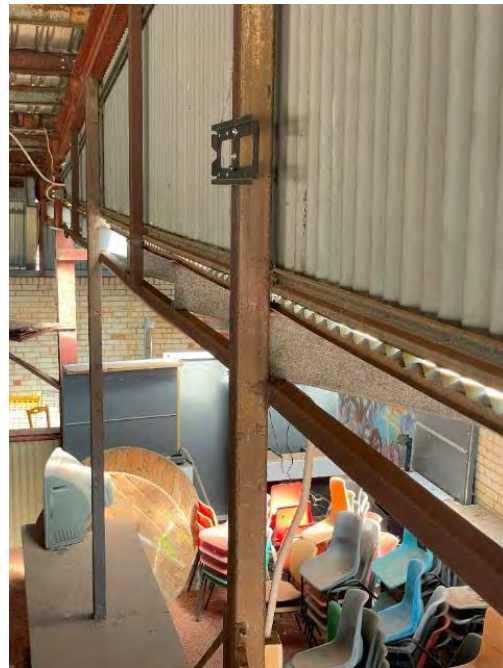

PICTURE 60



Existing Structure
Toodyay Race Club Precinct, Toodyay
Structural Report
24-0564



PICTURE 61



PICTURE 62



PICTURE 63



PICTURE 64



Existing Structure
Toodyay Race Club Precinct, Toodyay
Structural Report
24-0564



PICTURE 65



PICTURE 66



PICTURE 67

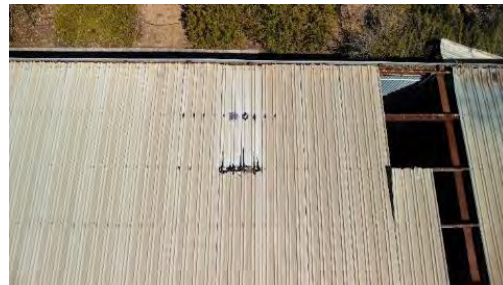

PICTURE 68



PICTURE 69



PICTURE 70



PICTURE 71



PICTURE 72



Existing Structure
Toodyay Race Club Precinct, Toodyay
Structural Report
24-0564



PICTURE 73



PICTURE 74



PICTURE 75



PICTURE 76



PICTURE 77



PICTURE 78



PICTURE 79



PICTURE 80



Existing Structure
Toodyay Race Club Precinct, Toodyay
Structural Report
24-0564



PICTURE 81



PICTURE 82



PICTURE 83



PICTURE 84



Existing Structure
Toodyay Race Club Precinct, Toodyay
Structural Report
24-0564



PICTURE 85



PICTURE 86



PICTURE 87



PICTURE 88



Existing Structure
Toodyay Race Club Precinct, Toodyay
Structural Report
24-0564



PICTURE 89



PICTURE 90



PICTURE 91



PICTURE 92